



Hematology Analyzer

Output Formats

Ref: RAA055BEN



Foreword

Table of Contents

Foreword..... Page 2

Introduction..... Page 3

Connections..... Page 4

General communication settings Page 5

ASTM-CI format..... Page 6

Revisions

Table 1: Revision table

Part number	Software version	Chapters	Date
RAA050AEN	V 1.0.x	All	April 2015
RAA055BEN	V1.0.x	Restrictions associated to version 1.0.x of the Yumizen , page 6	June 2015

Introduction

The Yumizen H500 communicates with the LIS using ASTM-CI (ASTM Common Implementation) protocol.

A connection between a computer (host) and a HORIBA Medical instrument can be performed when the protocol, the format description and the connection mode have been properly setup.

Table 2: Definitions

Term	Definition
<ACK>	Acknowledgment (ASCII Decimal 6)
[C1]	The most significant character of Checksum
[C2]	The least significant character of Checksum
[DATA]	The data contents of the record
<ENQ>	Inquire (ASCII Decimal 5)
<ETB>	End of Transmission Block (ASCII Decimal 23). For use only when a single record is too large to fit into one frame.
<ETX>	End of Text (ASCII Decimal 3). Required at the end of each record.
[frame number]	Single digit low-level frame number "0" to "7", starts with "1".
<LF>	Line Feed (ASCII Decimal 10).
<NAK>	Negative Acknowledgment (ASCII Decimal 21).
<STX>	Start of Frame (ASCII Decimal 2).
Communications packet	All framing required for transmission of data. This framing includes: <STX>[frame number][DATA] [<ETB> or <ETX>][C1][C2] <LF>
Component Field	One of several related pieces of information within a field.
Field	A specific location within a record for a piece of information, indicated by a field delimiter and position.
Frame	A complete communications packet.
LIS	Laboratory Information System
Message	A collection of related information; a group of records that begins with a "Header" record and ends with a "Terminator" record. A single record could theoretically constitute a message, but within this context, a message always contains multiple records.
<EOT>	End of Transmission (ASCII decimal 4)
<CR>	Carriage Return (ASCII decimal 13)

Table 2: Definitions

Term	Definition
Record	In reference to the low level protocol, a record is the message data (shown as [DATA]) as described within the communications packet. If the data is longer than 240 characters, then it must be split in two (or more) parts and sent in two (or more) communications packets. The intermediate packet uses the <ETB> character, and the ending packet uses the <ETX> character. No single communications packet contains more than one record. In reference to the message layer, a record can be one of the following codes: H (header), P (patient), O (order), R (result), L (terminator), C (comment).
Session	A total unit of communication activity used in this standard to indicate the events starting with the Establishment phase and ending with the Termination phase.
Test	A determination of a single analyte or a combination of values from other determinations or observations from which a variable or gradable result is derived.

Connections

Physical connection

1. RS232

All communications are expected to use the RS232 communication protocol, based on the Electronics Industries Association (EIA) standard RS232-C. As part of the conformance to this standard, the Yumizen H500 Data Management System is configured as Data Terminal Equipment (DTE).

The Yumizen H500 System is connected to the LIS via a DB-9 connector.

Table 3: DB9 connection

Pin (DB9) Yumizen Data Management	LIS Port Configuration	LIS Cable Must Provide
3	TXD	TXD
2	RXD	RXD
5	Ground	Ground

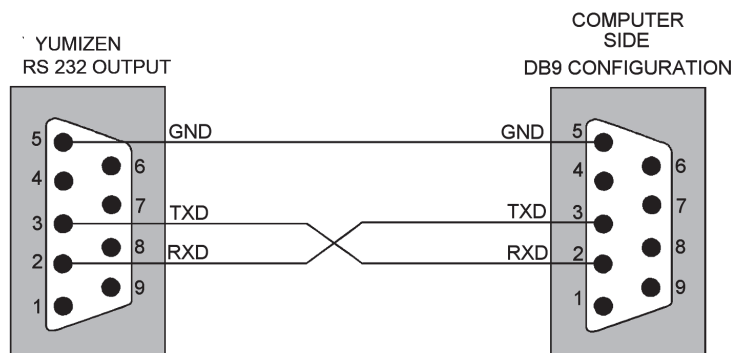

2. Ethernet (RJ45)

The implementation of network-based communication is based on the Windows Socket standard.

The data transmitted between the client and the server takes the form of ASTM high level packets.

The control characters are the same as those used for the Serial Interface.

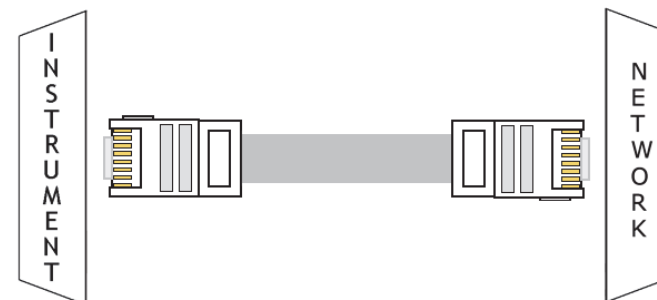

General communication settings

Access (Super User access rights) **Settings > System > General communication**

- Select **Yes** in the **LIS Connection** area.
- Select **Network** or **RS232** in the **LIS Connection Mode** area.

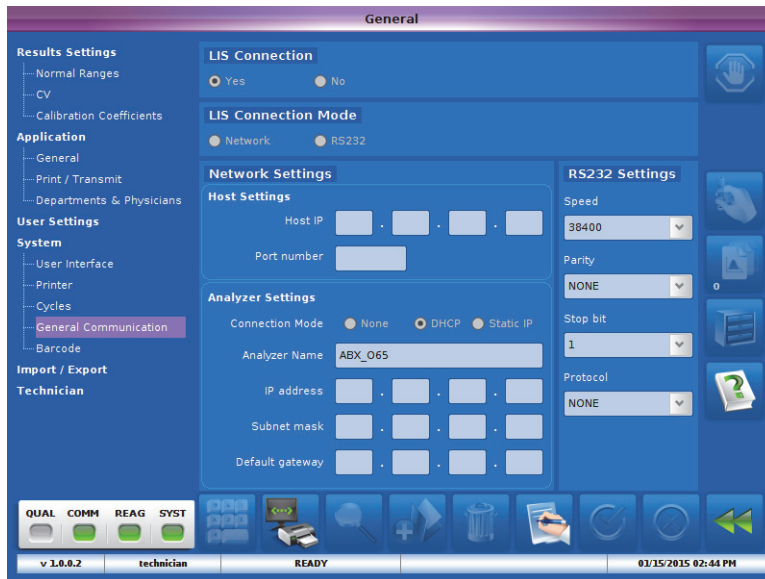

1. RS232

The instrument communication port must be set up in the **RS232 Settings** area:

- The baud speed value (1200, 2400, 4800, 9600, 19200, 38400, 57600, 115200)
- The parity value (None, Odd, Even)
- The bit stop value (1 or 2)
- The protocol value (None by default, Xon, Xoff)

2. Ethernet connection

In the **Host Settings** area, you must indicate:

- The **Host IP** address
- The **Port number** where the host is awaiting connection

In the **Analyzer Settings** area, you must indicate:

- The **Connection mode: None, DHCP** (default) or **Static IP**
- The **Analyzer Name**
- The **Analyzer IP address**
- The **Subnet Mask** IP address
- The **default Gateway** IP address



ASTM-CI format

The HORIBA Medical analyzers format responds to the ASTM specifications E-1381 & E-1394:

- E-1381: Standard specification for low level protocol to transfer messages between clinical and laboratory instruments and computer systems.
- E-1394: Standard specification for transferring information between clinical and laboratory instruments and computer systems.

Restrictions associated to version 1.0.x of the Yumizen

The Yumizen H500 in version 1.0.x can not transmit or receive from the LIS other characters than basic ASCII table:

("# \$% & '()* +, - . / : ; 0123456789 <=> @
 ABCDEFGHIJKLMNOPQRSTUVWXYZ [] ^ _
 `abcdefghijklmnopqrstuvwxyz? {} ~).



Any transaction that contains characters other than those mentioned above will be systematically rejected.

In particular, any analysis order sent by the LIS, and containing in one of the fields of the order (patient name, comments, service, ...) at least one character not in the basic ASCII table will be rejected.

Any analysis result containing in a field of the result or in the associated order (patient name, comments, service, ...) a character not in the basic ACSII table can not be transmitted to the LIS.

1. Connection specifications (ASTM E-1381)

1.1. Hardware and software characteristics

The default format for emitted character is 1 bit start, 8 data bits, No parity, 1 bit stop.
 The default communication speed is 38400 bauds.

Hardware settings of the interface:

- RS232 connection via a DB9 connector
- Ethernet connection via an RJ45 cable

1.2. Output data characteristics

Characters: ASCII

Maximum message length: 247 characters (240 useful characters).

The analyzer manages Xon/Xoff protocol.

1.3. Communication protocol

Table 4: Standard control characters

Control String	Hexadecimal value
<ENQ>	\$05
<ACK>	\$06
<NAK>	\$15
<STX>	\$02
<ETX>	\$03
<ETB>	\$17
<CR>	\$0D
<LF>	\$0A
<EOT>	\$04

1.3.1. Instrument/Host connection

Table 5: Typical discussion between the instrument and the host

Instrument	<>	Host
<ENQ>	>	
	<	<ACK>
<STX>1...Data...<CR><ETX>xx<CR><LF>	>	
	<	<ACK>
<STX>2...Data...<CR><ETX>xx<CR><LF>	>	
	<	<ACK>
<EOT>	>	



1.3.2. Discussion with conflict between the instrument and the host

Number of transmission if negative answer (NAK): 6
 Timeout if no response: 15 s (Automatic disconnection max. time)
 Retry timeout: None
 Special timing: None
 Description of other specific treatments: None

1.3.3. Defect packet during discussion between Instrument and Host

Table 6: Defect packet during discussion between Instrmnt and Host

Instrument	<>	Host
<ENQ>	>	
	<	<ACK>
<STX>1...Data...<CR><ETX>xx<CR><LF>	>	
	<	<NAK>
<STX>1...Data...<CR><ETX>xx<CR><LF>	>	
	<	<ACK>
<STX>2...Data...<CR><ETX>xx<CR><LF>	>	
	<	<ACK>
<EOT>	>	
Instrument	<>	Host

1.4. ASTM Data frame format

A sequential number located after the <STX> character is inserted into each Data frame. The low-level frame number is set to 1 when the transfer phase is initialized and is incremented by 1 for each frame up to 7 and then returns to 0. The low-level frame number allows the receiver to distinguish new and retransmitted frames, in case of retransmitted frame (after a <NAK> response from the host), the low-level frame number is not incremented: <STX>1...Data...<CR><ETX>xx<CR><LF>

Table 7: Frame format

ASTM field	Definition	Transmitted data	# of bytes	Comments
0	STX	\$02	1	
1	Frame number	1 to 7, 0, ...	1	Frame number is set to 1, incremented by 1 for each frame up to 7, and then returns to 0
2	Data message		240 max.	Header, Patient, Order, Result & Comment messages
3	End of data message ETX if end frame		1	
4	Checksum		2	
5	CRLF	\$0D \$0A	2	

1.4.1. Frame cheksum

According to ASTM E-1381, the frame cheksum (<STX>1...Data...<CR><ETX>xx<CR><LF>) is defined as modulo 256 of ASCII values sum between <STX> not included and <ETX> included characters: 1...Data...<CR><ETX>

2. Records general format specifications (ASTM E-1394)

Data frames encapsulate records defined by the ASTM E-1394 norm, records themselves encapsulate ASTM fields.

Table 8: ASTM Records

Record ID	ASTM Definition
H	Header
P	Patient
O	Order
R	Result
C	Comment



Table 8: ASTM Records

Record ID	ASTM Definition
Q	Query (Request information order)
M	Manufacturer information
L	Terminator record

- R (Result)
- L (Terminator)

2.1. Structure of Records

2.1.1. Structure of records for Order transmission

- H (Header)
- .. P (Patient)
-C (Patient Comments) Optional
-O (Order)
-

The transmission of an order without patient record is not allowed, but patient record can be empty. Example: <STX>2P|1<CR><ETX>BB<CR><LF>

2.1.2. Instrument Patient file modification by Host

- H (Header)
- P (Patient)
- C (Patient Comments) Optional
- L (Terminator)

2.1.3. Structure of records for Result transmission

- H (Header)
- P (Patient)
- C (Patient Comments) Optional
- .. O (Order)
- C (Order Comments) Optional
- M (Traceability) Optional
- M (Curves and Matrix Points) Optional (not available on Yumizen H500 OT)
- M (Curves and Matrix Points) Optional (not available on Yumizen H500 OT)
- M (Curves and Matrix Points) Optional (not available on Yumizen H500 OT)
- R (Result)



3. Description of Records

- Only fields described with their specified length are used by HORIBA Medical instruments.
- The length of a field can be less than the maximum value but must not be more.
- Only “Sample ID” and “Test” fields from the order record are mandatory, all other fields are optionals.
- Delimiters must be used even if a field is empty.
- Delimiters inside records are separated by “|” (ASCII \$7C).
- Delimiters inside fields are separated by “^” (ASCII \$5E).
- The ASTM-CI MUST use UTF-8 encoding for Alphanumeric fields.

3.1. Alphanumeric data

UTF-8 encoding is used for alphanumeric fields.
 When alphanumeric data is sent, all the characters below 0x20 are replaced by an escape sequence with the following format:

&Xhhhh&

«hhhh» is the Hexadecimal value of ASCII character completed with zero on 4 digits.

Example:

<ETB> should be replaced by: <&X0017&>

When alphanumeric data is received, the escape sequence "&Xhhhh&" is converted to the corresponding characters

When alphanumeric data is sent or received, all the delimiter characters use the

following format:

Table 9: Delimiter Character for Alphanumeric data

Delimiter	Escape sequence
Field delimiter	&F&
Component delimiter	&S&
Repeat delimiter	&R&
Escape delimiter	&E&

3.2. Records to send

The ASTM-CI controls all record's fields before sending a message.
 The ASTM-CI sends a record with all mandatory fields filled with valid values.
 Fields that are not used fields are sent empty.
 When sending records, the ASTM-CI sends only non-empty components, ie. without component delimiters for the last empty components of the field.

3.3. Received records

If a field value, length, delimiter of a received record does not correspond to the required input type, the ASTM-CI generates an error log, and ignores the corresponding record, with all following records of upper level, until a new record of same level is received.

Table 10: Received Records Errors

Messages	Definition
HL_UNEXPECTED_RECORD_ERROR	An unexpected (at wrong place in the frame) record has been received and ignored
HL_NOT_MANAGED_RECORD_ERROR	A record not managable has been received and ignored
HL_IGNORED_RECORD_ERROR	A record has been ignored (following a previous error)
HL_BYPASSED_RECORD_ERROR	A record of upper level has been ignored (following a previous error)



Table 10: Received Records Errors

Messages	Definition
HL_TERMINATOR_MISSING_ERROR	The Terminator record of a message is missing
HL_INVALID_ORDER_RECORD_ERROR	Order in response to a query is invalid, record ignored
HL_FIELD_TYPE_ERROR	Invalid field type, record ignored
HL_FIELD_LENGTH_ERROR	Invalid field length, field truncated or record ignored
HL_FIELD_VALUE_ERROR	Invalid field value, record ignored
HL_FIELD_REPEAT_DELIMITER_ERROR	Not allowed field repeat delimiter, record ignored
HL_FIELD_COMPONENT_DELIMITER_ERROR	Not allowed field component delimiter, field truncated

3.4. Header record

Table 11: Header record fields

ASTM field	Definition	Transmitted data	Field max. length	Input Type	Repeat Delimiter	Mandatory
6.1	Record Type ID	H	1	Fixed	No	Yes
6.2	Delimiter Definition	\^& Description : Field Delimiter \ Repeat Delimiter ^ Component Delimiter & Escape Delimiter	4	Fixed	No	Yes
6.3	Message Control ID	Not used				
6.4	Access Password	Not used				
6.5	Sender Name or ID (From device to host)	InstrumentCode^SerialNumber^Software version eg. : H500^9380BDED579C^v1.0.0	32 (5^15^10)	Alphanumeric^Alphanumeric^Alphanumeric	No	Yes
6.5	Sender Name or ID (From Host to device)	Host name	32	Alphanumeric	No	No
6.6	Sender Address	Not used				
6.7	Reserved Field	Not used				
6.8	Sender Telephone Nb	Not used				
6.9	Characteristic of Sender	Not used				
6.10	Receiver Name or ID (From device to host)	Host name	32	Alphanumeric	No	No
6.10	Receiver Name or ID (From Host to device)	InstrumentCode^SerialNumber^Software version H500^9380BDED579C^v1.0.0	32 (5^15^10)	Alphanumeric^Alphanumeric^Alphanumeric	No	No
6.11	Comment or Special Instruction	Not used				
6.12	Processing ID	« P » for a Patient analysis, « Q » for a QC, « D » for technician	1	Closed list	No	Yes
6.13	Version Number	« LIS2-A2 »	10	Fixed	No	Yes
6.14	Date and Time of Message	YYYYMMDDHHMMSS	14	Date and time	No	No

From device to Host

In case of remote command response, the field 6.5 should be an exact copy from the 6.10 field sent in the request by the host.

From Host to device

In case of request information response, the field 6.5 should be an exact copy from the 6.10 field sent in the request by the instrument.



3.5. Patient record

Table 12: Patient record fields

ASTM Field	ASTM definition	Instrument Definition	Transmitted data	Field max. length	Input Type	Repeat Delimiter	Mandatory
7.1	Record Type		P	1	Fixed	No	Yes
7.2	Sequence Number	Sequence of Patient record	1..99	2	Numeric	No	Yes
7.3	Practice Assigned Patient ID	Not used	Not used				
7.4	Laboratory Assigned Patient ID	PatientID	Patient Id	25	Alphanumeric	No	No
7.5	Patient ID N°3	Not used	Not used				
7.6	Patient Name	Last Name^First Name	Last Name^First Name	41 (20^20)	Alphanumeric	No	No
7.7	Mother's Maiden Name	Not used	Not used				
7.8	Birthdate	Birth Date^Age^Age unit	YYYYMMDD^AGE^U U : « Y » - year, « M » - month , « D » - day « M » - male « F » - female « U » - unknown	14 (8^3^1)	Date^ numeric^Closed List	No	No
7.9	Patient Sex	Gender		1	Closed list	No	No
7.10	Patient Race-Ethnic Origin	Patient Race	eg. : Human, Dog, Horse, etc.	20	Alphanumeric	No	No
7.11	Patient Address	Not used	Not used				
7.12	Reserved Field	Not used	Not used				
7.13	Patient Telephone Nb	Not used	Not used				
7.14	Attending Physician ID	Last Name^First Name	Last Name^First Name	41 (20^20)	Alphanumeric	No	No
7.15	Special Field 1	Not used	Not used				
7.16	Special Field 2	Not used	Not used				
7.17	Patient Height	Not used	Not used				
7.18	Patient Weight	Not used	Not used				
7.19	Patient's known or suspect diag	Not used	Not used				
7.20	Patient's active medication	Not used	Not used				
7.21	Patient's diet	Not used	Not used				
7.22	Practice Field 1	Not used	Not used				
7.23	Practice Field 2	Not used	Not used				
7.24	Admission and discharge	Not used	Not used				
7.25	Admission status	Not used	Not used				
7.26	Location	Department	eg. : Emergency	20	Alphanumeric	No	No
7.27	Nature of Alter. Diag. Code	Not used	Not used				
7.28	Alternative diag. code and class	Not used	Not used				



Table 12: Patient record fields

ASTM Field	ASTM definition	Instrument Definition	Transmitted data	Field max. length	Input Type	Repeat Delimiter	Mandatory
7.29	Patient Religion	Not used	Not used				
7.30	Marital Status	Not used	Not used				
7.31	Isolation Status	Not used	Not used				
7.32	Language	Not used	Not used				
7.33	Hospital Service	Not used	Not used				
7.34	Hospital Institution	Not used	Not used				
7.35	Dosage Category	Patient Type	eg. : Child 1, Child 2, Adult, etc	20	Alphanumeric	No	No

3.6. Order record

3.6.1. Description

Table 13: Order record fields

ASTM Field	ASTM definition	Instrument Definition	Transmitted data	Field max. length	Input Type	Repeat Delimiter	Mandatory
8.1	Record Type ID		O	1	Fixed	No	Yes
8.2	Sequence Number	Sequence of Order record	1..99	2	Numeric	No	Yes
8.3	Specimen ID	SampleID^^^	For open tube : eg. : 0123456789^^^	19(16^^^)	Alphanumeric^^^	No	No^^^
8.4	Device Specimen Id	Not used	Not used				
8.5	Universal Test ID	Tests	^^^Testname	6 (^^^3)	^^^Closed list	Yes	From device to host: ^^^Yes From Host to device: ^^^No
8.6	Priority	Emergency	« R » - for routine « S » - for STAT	1	Closed list	No	No
8.7	Requested / Ordered date/time	Order Date	YYYYMMDDHHMMSS	14	Date and time	No	No
8.8	Specimen Collection Date/ time	Collection Date	YYYYMMDDHHMMSS	14	Date and time	No	No
8.9	Collection End Time	Not used	Not used				



Table 13: Order record fields

ASTM Field	ASTM definition	Instrument Definition	Transmitted data	Field max. length	Input Type	Repeat Delimiter	Mandatory
8.10	Collection Volume	Not used	Not used				
8.11	Collector Id	Not used	Not used				
8.12	Action Code	Action code	From device to host: Not used From host to device: « A » - Add on existing order « N » - New order « C » - Cancel order	1	Closed list	No	From device to host: No From Host to device: Yes
8.13	Danger Code	Not used	Not used				
8.14	Relevant Clinical Information	Not used	Not used				
8.15	Date and time Specimen received	Received Date	YYYYMMDDHHMMSS	14	Date and time	No	No
8.16	Specimen Descriptor	Specimen Type and Specimen Liquid description	SpecimenType^^SpecimenLiquid SpecimenType : «BLOOD» «CTRL» SpecimenLiquid eg. : «CTRL LOW», «CTRL MEDIUM», «CTRL HIGH», etc	26(12^^12)	Openlist^^Alphanumeric	No	No^^No
8.17	Ordering Physician	Not used	Not used				
8.18	Physician Phone NB	Not used	Not used				
8.19	User Field 1	Not used	Not used				
8.20	User Field 2	Not used	Not used				
8.21	Laboratory Field 1	Not used	Not used				
8.22	Laboratory Field 2	Not used	Not used				
8.23	Date and time result reported	Not used	Not used				
8.24	Instrument charge to computer system	Not used	Not used				



Table 13: Order record fields

ASTM Field	ASTM definition	Instrument Definition	Transmitted data	Field max. length	Input Type	Repeat Delimiter	Mandatory
8.25	Device Section Id	Not used	Not used				
8.26	Report Types		<u>From device to host:</u> « F » - Final <u>From host to device:</u> « Q » - response to request information « Z » - no record of this patient « Y » - no test for this record	1	Closed list	No	Yes
8.27	Reserved Field	Not used	Not used				
8.28	Location or Ward	Not used	Not used				
8.29	Nosocomial Service	Not used	Not used				
8.30	Specimen Service	Not used	Not used				
8.31	Specimen Institution	Not used	Not used				

3.6.2. «Order» record fields specifications

The order must follow the following:

- «SampleID» data of «Specimen ID» field (8.3) match the «SampleID» data of the pending query.
- At least one of «Universal Test ID» field (8.5) shall contain a «TestName» data with one of the following values : CBC, DIF.
- In case of several «Universal Test ID» field (8.5), with at least one with a «DIF» TestName, and at least another one with a «CBC» TestName, the requested analysis is set to DIF.
- «Action code» field (8.12) is "N" (New order).
- «Report Types» field (8.26) is one of the following values:
 - «Q» (response to request information)
 - «Z» (no record for this patient)
 - «Y» (no test for this record)

Otherwise, the received order is ignored.

If a received «Order» record is ignored, the software sends in return a «Result» record with the following specifications:

- «Record Types» field (8.26) is set to «X» (order cannot be done).
- The result does not include «Traceability manufacturer message» record.
- The result contain a record for to the WBC parameter, with «Data or Measurement Value» field (9.4) empty, and «Result Status» field (9.9) set to «X» (Order cannot be done)



3.7. Result Record

Table 14: Result record fields

ASTM Field	ASTM definition	Instrument Definition	Transmitted data	Field max. length	Input Type	Repeat Delimiter	Mandatory
9.1	Record Type ID		R	1	Fixed	No	Yes
9.2	Sequence Number	Sequence of Result record	1..99	2	Numeric	No	Yes
9.3	Universal Test ID	Test information	^^^English result name^LOINC^Dil Description : Result name : in English. LOINC <u>from device to host</u> : Code associated with the result name, if available. LOINC <u>from host to device</u> : Not used Dil : Dilution factor (denominator)	22(^^^5^7^5)	^^^Open list^Open list^Numeric	No	^^^Yes^No^No
9.4	Data or Measurement Value	Test result	eg. : 1.23, data observation	16	AlphaNumeric	No	No
9.5	Units	Test units	Unit text (ISO 2955 or specific)	10	Open list (refer to Parameters presentation on page 22)	No	Yes but No if observation
9.6	Reference Ranges	<u>From device to host</u> : Reference Ranges <u>From Host to device</u> : Not used	<u>From device to host</u> : Low ranges to high range <u>From Host to device</u> : Not used		Alphanumeric	Yes	No
9.7	Result Abnormal Flag	<u>From device to host</u> : Result Abnormal Flag <u>From Host to device</u> : Not used	<u>From device to host</u> : « L » - below low normal « H » - above high normal « LL » - below panic normal « HH » - above panic normal « < » - below absolute low « > » - above absolute high « A » - abnormal « N » - normal <u>From Host to device</u> : Not used	2	Closed list	No	Yes
9.8	Nature of abnormality Testing	Not used	Not used				
9.9	Result Status	<u>From device to host</u> : Result Status <u>From Host to device</u> : Not used	<u>From device to host</u> : « W » - Warning (suspicion on validity) « X » - order cannot be done (result) «F» - Final Result <u>From Host to device</u> : Not used	1	Closed list	No	Yes



Table 14: Result record fields

ASTM Field	ASTM definition	Instrument Definition	Transmitted data	Field max. length	Input Type	Repeat Delimiter	Mandatory
9.10	Date of Change in Norm. Values	Not used	Not used				
9.11	Operator Identification	<u>From device to host:</u> Login^^User profile <u>From Host to device:</u> Not used	<u>From device to host:</u> Login^^User profile or LastName FirstName^^User profile eg. :BOND^^Technician or JEAN DURAND^^Technician <u>From Host to device:</u> Not used	63(41^^20)	Alphanumeric ^^ Alphanumeric	No	Yes^^No
9.12	Date/Time Test Starting	Date/Time Test Starting	YYYYMMDDHHMMSS	14	Date	No	Yes
9.13	Date/Time Test Completed	Date/Time Test Completed	YYYYMMDDHHMMSS	14	Date	No	No
9.14	Device Identification	<u>From device to host:</u> Serial Number <u>From Host to device:</u> Not used	<u>From device to host:</u> eg. : 9380BDED579C <u>From Host to device:</u> Not used	15	Alphanumeric	No	No

From Host to device: The result Frame is used for history purpose.



3.8. Comment record

3.8.1. Description

Table 15: Comment record fields

ASTM Field	ASTM definition	Instrument Definition	Transmitted data	Field max. length	Input Type	Repeat Delimiter	Mandatory
10.1	Record Type ID		C	1	Fixed	No	Yes
10.2	Sequence Number	Sequence of Comment record	1..99	2	Numeric	No	Yes
10.3	Comment source	Comment source	« I » - Clinical device system	1	Closed list	No	Yes
10.4	Comment text	Comment information	<u>From device to host:</u> For result comment (after R frame) : Alarm	<u>From device to host:</u> 20	<u>From device to host:</u> Open list	Yes	Yes
			For order comment (after O frame): AlarmType^MeasurementType^Alarm <i>example:</i> "ANALYTICAL^RBC^FEW_EVENTS"	52(20^10^20)	Open list^Open list^Open list	Yes	Y^No^Y
			For patient comment or sample comment (after P or O frame): Free text	200	Alphanumeric	No	Yes
			<u>From Host to device:</u> Comments	<u>From Host to device:</u> 200	<u>From Host to device:</u> Alphanumeric	<u>From Host to device:</u> No	<u>From Host to device:</u> Yes
10.5	Comment type	Comment type	« I » - Device flag comment	1	Closed list	No	Yes



3.8.2. Alarm Specifications

The «Comment text» field (10.4) can contain an Alarm Type data as follows:

- «CONDITIONS» for alarms linked to analysis conditions such as Blank failed, Reagent expired, ...
- «NON_COMPLIANT_DATA» for alarms linked to the calculation regarding data such as Hgb instability, Noise, Counting instability, Abnormal NEU distribution ...
- «SUSPECTED_PATHOLOGY» for suspected pathologies alarms such as Leukocytosis, Large Immature Cells, ...
- «CONTROL_FAILED» for alarms due to bad control result.

The «Comment text» field (10.4) can contain a Measurement Type data as follows:

- «HGB» if the alarm is linked to the hemoglobin measurement.
- «LMNEB» if the alarm is linked to the white blood cells measurement.
- «RBC» if the alarm is linked to the red blood cells measurement.
- «PLT» if the alarm is linked to the platelets measurement.
- «RBC/PLT» if the alarm is linked to RBC and PLT measurement such as MCH.

The «Comment text» field (10.4) can contain one of the analysis Alarms values specified in [Alarms and Pathologies](#), page 23

- The default condition in case of "CONDITIONS" alarm type, truncated to 20 characters (for exemple REAGENT_EXPIRED)
- The reason of the controle failure in case of CONTROL_FAILED alarm type, truncated to 20 characters (for exemple EOS%_ABOVE_TOLERANCE, RDW-CV_DELOW_TOLERAN)

3.9. Request information record

Table 16: Request information record fields

ASTM Field	ASTM definition	Instrument Definition	Transmitted data	Field max. length	Input Type	Repeat Delimiter	Mandatory
11.1	Record Type ID		Q	1	Fixed	No	Yes
11.2	Sequence Number	Sequence of Request record	1..99	2	Numeric	No	Yes
11.3	Starting Range ID Number	^SampleID^^^	For open tube : eg. : ^01234567^^^	20(^16^^^)	^Alphanumeric^^^	No	^Yes^^^
11.4	End Of identifier List	Not used	Not used				
11.5	Universal Test ID	ALL	ALL	3	Fixed	No	Yes
11.6	Time limits	Not used	Not used				
11.7	Time Max limits	Not used	Not used				



Table 16: Request information record fields

3.10. Traceability record

ASTM Field	ASTM definition	Instrument Definition	Transmitted data	Field max. length	Input Type	Repeat Delimiter	Mandatory
11.8	Time Min limits	Not used	Not used				
11.9	Physician Name	Not used	Not used				
11.10	Telephone Number	Not used	Not used				
11.11	Reserved for User	Not used	Not used				
11.12	Reserved for User	Not used	Not used				
11.13	Request Information Status Codes	Request Information Status	« O » request for test information	1	Fixed	No	Yes

Table 17: «Manufacturer message» record fields

ASTM Field	ASTM definition	Instrument Definition	Transmitted data	Field max. length	Input Type	Repeat Delimiter	Mandatory
14.1	Record Type ID		M	1	Fixed	No	Yes
14.2	Sequence Number	Sequence of Manufacturer record	1..99	2	Numeric	No	Yes
14.3	Message type	Message type	« REAGENT »	10	Closed list	No	Yes
14.4	Traceability name	Traceability name	Reagent name: «CLEANER», «DILUENT», «LYSE»	20	Open list	Yes	Yes
14.5	Traceability Information	ReagentID^Loaded date/ time^ExpirationDate	eg. : 120130H1^20120327151737^20120727	33 (9^14^8)	Alphanumeric	Yes	Yes^No^Yes

3.11. Terminator record



Table 18: Terminator record fields

ASTM Field	ASTM definition	Instrument Definition	Transmitted data	Field max. length	Input Type	Repeat Delimiter	Mandatory
12.1	Record type		L	1	Fixed	No	Yes
12.2	Sequence number	1..99	1..99	2	Numeric	No	Yes
12.3	Termination code	Not used					



4. Special characteristics for HORIBA Medical data

4.1. Yumizen Parameters Presentation

Table 19: Parameters presentation

Parameter	Universal Test ID field 9.3	Units field 9.5			
		conventional	International	mmol	Japanese
White Blood Cell	WBC	10 ³ /mm ³	10 ⁹ /L	10 ⁹ /L	10 ² /mm ³
Lymphocytes #	LYM#	10 ³ /mm ³	10 ⁹ /L	10 ⁹ /L	10 ² /mm ³
Lymphocytes %	LYM%	%	%	%	%
Monocytes #	MON#	10 ³ /mm ³	10 ⁹ /L	10 ⁹ /L	10 ² /mm ³
Monocytes %	MON%	%	%	%	%
Neutrophils #	NEU#	10 ³ /mm ³	10 ⁹ /L	10 ⁹ /L	10 ² /mm ³
Neutrophils %	NEU%	%	%	%	%
Eosinophils #	EOS#	10 ³ /mm ³	10 ⁹ /L	10 ⁹ /L	10 ² /mm ³
Eosinophils %	EOS%	%	%	%	%
Basophils #	BAS#	10 ³ /mm ³	10 ⁹ /L	10 ⁹ /L	10 ² /mm ³
Basophils %	BAS%	%	%	%	%
Large Immature cells #	LIC#	10 ³ /mm ³	10 ⁹ /L	10 ⁹ /L	10 ² /mm ³
Large Immature cells %	LIC%	%	%	%	%
Red Blood Cell	RBC	10 ⁶ /mm ³	10 ¹² /L	10 ¹² /L	10 ⁴ /mm ³
Hemoglobin	HGB	g/dL	g/L	mmol/L	g/dL
Hematocrit	HCT	%	L/L	L/L	%
Mean Corpuscular Volume	MCV	μm ³	fL	fL	μm ³
Mean Corpuscular Hemoglobin	MCH	pg	pg	fmol	pg
Mean Corpuscular Hemoglobin Concentration	MCHC	g/dL	g/L	mmol/L	g/dL
Red Distribution Width	RDW-CV	%	%	%	%
Red Distribution Width Standard Deviation	RDW-SD	μm ³	fL	fL	μm ³
Platelets	PLT	10 ³ /mm ³	10 ⁹ /L	10 ⁹ /L	10 ⁴ /mm ³

Table 19: Parameters presentation

Parameter	Universal Test ID field 9.3	Units field 9.5			
		conventional	International	mmol	Japanese
Mean Platelet Volume	MPV	μm ³	fL	fL	μm ³
Plateletcrit	PCT	%	10 ⁻² /L	10 ⁻² /L	%
Platelet Distribution Width	PDW	%	%	%	%
Platelets - Large Cell Count	PL-LCC	10 ³ /mm ³	10 ⁹ /L	10 ⁹ /L	10 ⁴ /mm ³
Platelets - Large Cell Ratio	PL-LCR	%	%	%	%



4.2. Alarms and Pathologies

4.2.1. Suspicion and Reject

When a result is suspected of being abnormal or false, it is not reliable and the instrument returns a flag in field 9.9 (Refer to [Table 14 - Result record fields](#), page 16.).

4.2.2. Normal and Panic ranges

Flags when result exceeds Normal or Panic ranges are transmitted through field 9.7, they should be compared, to get a full result information, to the ranges set by the user (Refer to [Table 14 - Result record fields](#), page 16.).

4.2.3. Analysis alarms

The analysis alarms (Refer to [Table 20 - Analysis alarms list](#), page 23.) are transmitted to a comment record.
It follows the order record.

Table 20: Analysis alarms list

Parameter	Transmitted data	Description
HGB	BLK_OUT_OF_RANGE	HGB blank out of range
HGB	HGB_INSTABILITY	Ten consecutive HGB measurements are not enough consistent to provide a reliable result.
HGB	BLANK_INSTABILITY	The two consecutive HGB blank measurements results are out of a reliable range.
HGB	OUT_OF_LINEARITY_RAN	HGB measurement out of linearity range
LMNEB	NOISE	Background noise
LMNEB	LL_OR_LL1_INTERFEREN	Lymphocyte interferences
LMNEB	MON_INTERFERENCE	Monocyte interferences
LMNEB	SMALL_NEU	Abnormal Neutrophil distribution
LMNEB	SEP_MON_NEU	Abnormal Monocyte/Neutrophil distribution
LMNEB	SEP_NEU_EOS	Abnormal Neutrophil/Eosinophil distribution
LMNEB	SEP_LYM_MON	Abnormal Lymphocyte/Monocyte distribution
LMNEB	ALY	Atypical Lymphocyte
LMNEB	LMNE_OUT_OF_LINEARIT	Out of linearity range
LMNEB	LIGHT_SHIFT	Optical bench light error
LMNEB	ZERO_COUNTING	Incorrect sampling

Table 20: Analysis alarms list

Parameter	Transmitted data	Description
LMNEB	COUNTING_INSTABILITY	Counting instability
LMNEB	CORRELATION_TOO_LOW	Poor correlation between optical and resistive measurements
RBC	HCT_OUT_OF_LINEARITY	HCT out of linearity range
RBC	ZERO_COUNTING	Incorrect sampling
RBC	BIG CELLS EXCESS	Nucleated cells interference
RBC	PC_MODE	PLT Concentrate Mode
RBC	RBC_DBL	RBC double population
RBC	RBC_COUNT_TOO_LOW	Low RBC count
RBC	RBC_OUT_OF_LINEARITY	RBC out of linearity range
PLT	SEP_RBC_PLT	RBC/PLT interference
PLT	SCH	Schistocyte presence
PLT	SCL	Small Cells presence
PLT	PLT_COUNT_TOO_LOW	Low PLT count
PLT	ZERO_COUNTING	Incorrect sampling
PLT	PLT_OUT_OF_LINEARITY	PLT out of linearity range
PLT	COUNTING_INSTABILITY	Counting instability
PLT	NOISE	background noise



An analysis alarms comment record is structured as follows:

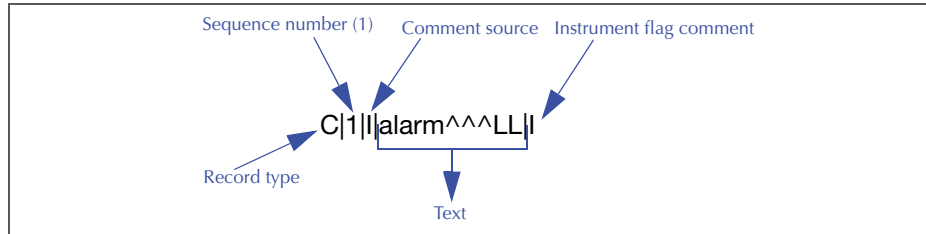

5. Example of data frame

5.1. Example of a query with the response

Table 21: Query and response

```

<- Instrument
-> Host
<- <ENQ>
-> <ACK>
<- <STX>1H|\^&|||H500^001YOXH00031^1.0.0.6|||||P|LIS2-A2|20150323160052<CR><ETX>34<CR><LF>
-> <ACK>
<- <STX>2Q|1|^289645146||ALL|||||O<CR><ETX>F7<CR><LF>
-> <ACK>
<- <STX>3L|1|N<CR><ETX>06<CR><LF>
-> <ACK>
<- <EOT>
-> <ENQ>
<- <ACK>
-> <STX>1H|\^&|||HCM|||||P|LIS2-A2|20150323160111<CR><ETX>51<CR><LF>
<- <ACK>
-> <STX>2P|1||2||BOND^JAMES||19770526|M|||||<CR><ETX>24<CR><LF>
<- <ACK>
-> <STX>3O|1|289645146||^DIF|R|20150323160111|||||N|||||Q|||||<CR><ETX>C0<CR><LF>
<- <ACK>
-> <STX>4L|1|<CR><ETX>B9<CR><LF>
<- <ACK>
-> <EOT>
    
```



5.2. Example of result sent by instrument

Table 22: Example of result sent by instrument

```

<- Instrument
-> Host
<- <ENQ>
-> <ACK>
<- <STX>1H|^&||H500^001YOXH00031^1.0.0.6|||||D|LIS2-A2|20150323160731<CR><ETX>2C<CR><LF>
-> <ACK>
<- <STX>2P|1||123||Dylan^Bob||19900302|M|||||||||||||||||MAN||<CR><ETX>F3<CR><LF>
-> <ACK>
<- <STX>3O|1|145654|^DIF|R|20150323160230|||||BLOOD|||||F||||<CR><ETX>8D<CR><LF>
-> <ACK>
<-
<STX>4C|1||CONDITIONS^CONTROL_FAILED\NON_COMPLIANT_DATA^LMNE^SEP_MON_NEU\NON_COMPLIANT_DATA^LMNE^NOISE\NON_COMPLIANT_DATA^LMNE^LG_OR_LG1_INTERFERE\NON_COMPLIANT_DATA^LMNE^LG_OR_LG1_INTERFERE\SUSPECTED_PATHOLOGY^MICROCYTOSIS\SUSPECTED_PATHOLOGY<ETB>1F<CR><LF>
-> <ACK>
<-
<STX>5^ANISOCYTOSIS\SUSPECTED_PATHOLOGY^COLD_AGGLUTININS\SUSPECTED_PATHOLOGY^ERBS\SUSPECTED_PATHOLOGY^LARGE_IMMATURE_CELLS|<CR><ETX>A7<CR><LF>
-> <ACK>
<-
<STX>6M|1|REAGENT\CLEANER\DILUENT\LYSE|1501061^20150306000000^20150606\141215H1^20150317110528^20150917\141215M11^20150314163050^20150514<CR><ETX>F2<CR><LF>
-> <ACK>
<- <STX>7R|1|^PCT^51637-7|0.002|10E-2L/L|0.002 - 0.005|N||F||technician^^TECHNICIAN|20150323160230||<CR><ETX>E3<CR><LF>
-> <ACK>
<- <STX>0R|2|^NEU#^751-8|4.12|10E9/L|2.00 - 7.50|N||W||technician^^TECHNICIAN|20150323160230||<CR><ETX>B4<CR><LF>
-> <ACK>
<- <STX>1R|3|^MCV^787-2|73.9|fL|80.0 - 100.0|L||F||technician^^TECHNICIAN|20150323160230||<CR><ETX>10<CR><LF>
-> <ACK>
<- <STX>2R|4|^P-LCR^48386-7|33.9|%|0.0 - 0.3|H||F||technician^^TECHNICIAN|20150323160230||<CR><ETX>13<CR><LF>
-> <ACK>
<- <STX>3R|5|^NEU%^770-8|64.0|%|0.0 - 100.0|N||W||technician^^TECHNICIAN|20150323160230||<CR><ETX>7E<CR><LF>
-> <ACK>

```

Table 22: Example of result sent by instrument

```

<- <STX>4R|6|^RDW-CV^788-0|17.4|%|11.0 - 16.0|H||F||technician^^TECHNICIAN|20150323160230||<CR><ETX>62<CR><LF>
-> <ACK>
<- <STX>5R|7|^RBC^789-8|4.5|1|10E12/L|3.80 - 6.50|N||F||technician^^TECHNICIAN|20150323160230||<CR><ETX>B9<CR><LF>
-> <ACK>
<- <STX>6R|8|^MPV^32623-1|9.9|fL|6.0 - 11.0|N||F||technician^^TECHNICIAN|20150323160230||<CR><ETX>F0<CR><LF>
-> <ACK>
<- <STX>7R|9|^P-LCC^N/A|78.8|10E9/L|0.0 - 0.3|H||F||technician^^TECHNICIAN|20150323160230||<CR><ETX>98<CR><LF>
-> <ACK>
<- <STX>0R|10|^MON#^742-7|0.08|10E9/L|0.20 - 1.00|L||W||technician^^TECHNICIAN|20150323160230||<CR><ETX>D8<CR><LF>
-> <ACK>
<- <STX>1R|11|^WBC^6690-2|6.92|10E9/L|4.00 - 10.00|N||W||technician^^TECHNICIAN|20150323160230||<CR><ETX>19<CR><LF>
-> <ACK>
<- <STX>2R|12|^PLT^777-3|232.7|10E9/L|150.0 - 500.0|N||F||technician^^TECHNICIAN|20150323160230||<CR><ETX>52<CR><LF>
-> <ACK>
<- <STX>3R|13|^LIC%^55433-7|7.3|%|0.0 - 3.0|H||W||technician^^TECHNICIAN|20150323160230||<CR><ETX>B6<CR><LF>
-> <ACK>
<- <STX>4R|14|^MON%^5905-5|1.2|%|0.0 - 100.0|N||W||technician^^TECHNICIAN|20150323160230||<CR><ETX>AC<CR><LF>
-> <ACK>
<- <STX>5R|15|^LIC%^55432-9|0.47|10E9/L|0.00 - 0.30|H||W||technician^^TECHNICIAN|20150323160230||<CR><ETX>7F<CR><LF>
-> <ACK>
<- <STX>6R|16|^LYM#^731-0|1.94|10E9/L|1.00 - 4.00|N||W||technician^^TECHNICIAN|20150323160230||<CR><ETX>ED<CR><LF>
-> <ACK>
<- <STX>7R|17|^PDW^51631-0|14.1|fL|11.0 - 18.0|N||F||technician^^TECHNICIAN|20150323160230||<CR><ETX>6F<CR><LF>
-> <ACK>
<- <STX>0R|18|^HGB^718-7|142|g/L|130 - 170|N||F||technician^^TECHNICIAN|20150323160230||<CR><ETX>9E<CR><LF>
-> <ACK>
<- <STX>1R|19|^LYM%^736-9|30.0|%|0.0 - 100.0|N||W||technician^^TECHNICIAN|20150323160230||<CR><ETX>B7<CR><LF>
-> <ACK>

```



Table 23: Example of QC result

```

<- <STX>0R|10|^^^MON%^5905-5|9.2|%|0.7 -
16.7|N|F|technician^^TECHNICIAN|20150323160321||<CR><ETX>80<CR><LF>
-> <ACK>
<- <STX>1R|11|^^^LYM#^731-0|1.89|10E9/L|1.59 -
2.99|N|F|technician^^TECHNICIAN|20150323160321||<CR><ETX>F5<CR><LF>
-> <ACK>
<- <STX>2R|12|^^^HGB^718-7|142|g/L|133 -
143|N|F|technician^^TECHNICIAN|20150323160321||<CR><ETX>9E<CR><LF>
-> <ACK>
<- <STX>3R|13|^^^LYM%^736-9|27.3|%|23.7 -
39.7|N|F|technician^^TECHNICIAN|20150323160321||<CR><ETX>CA<CR><LF>
-> <ACK>
<- <STX>4R|14|^^^BAS%^706-2|2.5|%|0.5 -
8.5|N|F|technician^^TECHNICIAN|20150323160321||<CR><ETX>04<CR><LF>
-> <ACK>
<- <STX>5R|15|^^^BAS#^704-7|0.17|10E9/L|0.02 -
0.62|N|F|technician^^TECHNICIAN|20150323160321||<CR><ETX>C5<CR><LF>
-> <ACK>
<- <STX>6R|16|^^^MCH^785-6|31.5|pg|27.6 -
31.6|N|F|technician^^TECHNICIAN|20150323160321||<CR><ETX>3B<CR><LF>
-> <ACK>
<- <STX>7R|17|^^^MCHC^786-4|426|g/L|339 -
399|N|F|technician^^TECHNICIAN|20150323160321||<CR><ETX>0E<CR><LF>
-> <ACK>
<- <STX>0R|18|^^^HCT^4544-3|0.333|L/L|0.355 -
0.395|N|F|technician^^TECHNICIAN|20150323160321||<CR><ETX>ED<CR><LF>
-> <ACK>
<- <STX>1R|19|^^^EOS#^711-2|0.51|10E9/L|0.04 -
0.44|N|F|technician^^TECHNICIAN|20150323160321||<CR><ETX>CF<CR><LF>
-> <ACK>
<- <STX>2R|20|^^^EOS%^713-8|7.4|%|0.1 -
6.7|N|F|technician^^TECHNICIAN|20150323160321||<CR><ETX>14<CR><LF>
-> <ACK>
<- <STX>3L|1|N<CR><ETX>06<CR><LF>
-> <ACK>
<- <EOT>
    
```

