



HORIBA ABX

Diagnostics

RAA034CEN

OUTPUT FORMATS

PENTRA 120 DX / DF

Explore the future

HORIBA GROUP

Table of contents

- > "Introduction", page 3
- > "Physical connection (RS232)", page 4
- > "ABX Format", page 5

Introduction

ABX Format is currently supported to be compliant with existing connections, but will not be supported on future generation of instrument. Argos Format is not supported on new system generation.

Different protocols can be used on HORIBA ABX instrument, a connection between a computer (host) and an HORIBA ABX instrument can be performed when the protocol, the format description and the connection mode are properly set up.

Table 1: Definitions

Term	Definition
<ACK>	Acknowledgment (ASCII Decimal 6)
[C1]	The most significant character of Checksum
[C2]	The least significant character of Checksum
[DATA]	The data contents of the record
<ENQ>	Inquire (ASCII Decimal 5)
<ETB>	End of Transmission Block (ASCII Decimal 23). For use only when a single record is too large to fit into one frame.
<ETX>	End of Text (ASCII Decimal 3). Required at the end of each record.
[frame number]	Single digit frame number "0" to "7", starts with "1".
<LF>	Line Feed (ASCII Decimal 10).
<NAK>	Negative Acknowledgment (ASCII Decimal 21).
<STX>	Start of Frame (ASCII Decimal 2).
Communications packet	All framing required for transmission of data. This framing includes: <STX>[frame number][DATA] [<ETB> or <ETX>][C1][C2] <LF>
Component Field	One of several related pieces of information within a field.
Download	The transmission of data from the LIS to the PentraDX Data Management System.
Field	A specific location within a record for a piece of information, indicated by a field delimiter and position.

Table 1: Definitions

Term	Definition
Frame	A complete communications packet.
LIS	Laboratory Information System
Message	A collection of related information; a group of records that begins with a «Header» record and ends with a «Terminator» record. A single record could theoretically constitute a message, but within this context, a message always contains multiple records.
Receiver	The device that responds to the sender. The receiver in this document is either the PentraDX Data Management System or the LIS.
<EOT>	End of Transmission (ASCII decimal 4)
<CR>	Carriage Return (ASCII decimal 13)
Record	In reference to the low level protocol, a record is the message data (shown as [DATA]) as described within the communications packet. If the data is longer than 240 characters, then it must be split into two (or more) parts and sent in two (or more) communications packets. The intermediate packet uses the <ETB> character, and the ending packet uses the <ETX> character. No single communications packet contains more than one record. In reference to the message layer, a record can be one of the following codes: H (header), P (patient), O (order), R (result), L (terminator), C (comment).
Repeat Field	An additional field of the preceding type when indicated by a repeat delimiter. The PentraDX Data Management System parses and may produce repeat fields in the Universal Test ID field of a Test Order Record or the Value field of the Result Record, but ignores other occurrences of repeat fields.
Sender	The device that has a message to send and initiate the transmission process, in this case between the LIS and the PentraDX Data Management System. The sender in this document is either the PentraDX Data Management System or the LIS.
Session	A total unit of communication activity used in this standard to indicate the events starting with the Establishment phase and ending with the Termination phase.
Test	A determination of a single analyte or a combination of values from other determinations or observations from which a variable or gradable result is derived.
Upload	The transmission of data from the PentraDX Data Management System to the LIS.

Physical connection (RS232)

Instrument RS DB25

- GND: ground
- TXD: transmission
- RXD: reception

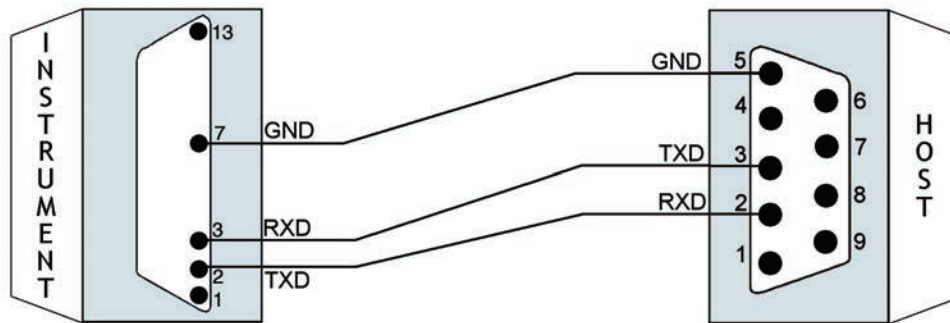

ABX Format

1. Overview

- ABX format supports unidirectionnal or bidirectionnal connections.
- ABX format can have a different number of fields according to the transmitted items set up by the user (results, curves, flags, etc...) or according to the type of cycle.
- Fields sequence is not fixed.
- The result identifier is different according to the type of result: patient result («RESULT»), re-run result (RES-RR), QC result (QC-RES) etc... (See Table 4, “Data transmitted by the host to the analyzer”, page 8).

2. Protocol description

2.1. Unidirectionnal mode

2.1.1. Typical unidirectionnal transmission from Instrument to Host

Table 2: Typical unidirectionnal transmission from Instrument to Host

Instrument	<>	Host	Comment
<STX> + RESULT + <ETX>	>		

2.1.2. Typical unidirectionnal transmission from Instrument to Host with «SOH»\»EOT»

«SOH»\»EOT» option must be enabled on the instrument.

Table 3: Typical unidirectionnal transmission with «SOH»\»EOT» from Instrument to Host

Instrument	<>	Host	Comment
<SOH>	>		Instrument takes the Line
<STX> + RESULT + <ETX>	>		
	.		
	.		
	.		
<STX> + RESULT + <ETX>	>		
<EOT>	>		Instrument frees the Line

2.2. Bidirectionnal mode

2.2.1. Typical bidirectionnal transmission from Host to Instrument

Table 4: Typical transmission from Host to Instrument

Host	< >	Instrument	Comment
<SOH>	>		Host takes the Line
	<	<ENQ>	
<STX> + FILE + <ETX>	>		
	<	<ACK>	
	.		
	.		
	.		
<STX> + END + <ETX>	>		Host frees the Line
	<	<ACK>	

2.2.2. Typical bidirectionnal transmission from Instrument to Host

Table 5: Typical transmission from Instrument to Host

Instrument	< >	Host	Comment
<SOH>	>		Instrument takes the Line
	<	<ENQ>	
<STX> + RESULT + <ETX>	>		
	<	<ACK>	
	.		
	.		

Table 5: Typical transmission from Instrument to Host

Instrument	< >	Host	Comment
	.		
<STX> + END + <ETX>	>		Instrument frees the Line
	<	<ACK>	

2.3. Conflict management

Number of transmission if negative answer (NAK): 1
 Timeout: 15s

In case of SOH/SOH conflict, priority is given to Host. After an adjustable delay (8s by default) and if Host has not re-sent a SOH, instrument tries to send SOH again until timeout. This is done until automatic disconnection max. time is reached.

3. Message structure

3.1. Lines structure

HEADER:

- STX
- Size + carriage return (Size: 5 bytes representing the total amount of the data except STX and ETX).
- Identifier followed by a Load Type + carriage return (Load: 8 character string preceded by a blank indicating the type of data).

VARIABLE PART:

- Identifier followed by the Information associated to the Load Type + carriage return (Identifier: 1 byte moving about \$21 to \$FF, it describes the information type which follows this indicator, always followed by a blank character \$20).
- Remainder of the other Identifiers and Information associated to the Load Type + carriage returns.
- Other Load Type blocs + Associated Information

POST-HEADER:

- Identifier followed by CheckSum + carriage return (CheckSum: Sum modulo 65536 of all characters except ETX, STX and all information about checksum (identifier - space - checksum - carriage return) in the hexadecimal format on 4 bytes, preceded by a blank character \$20).
- ETX

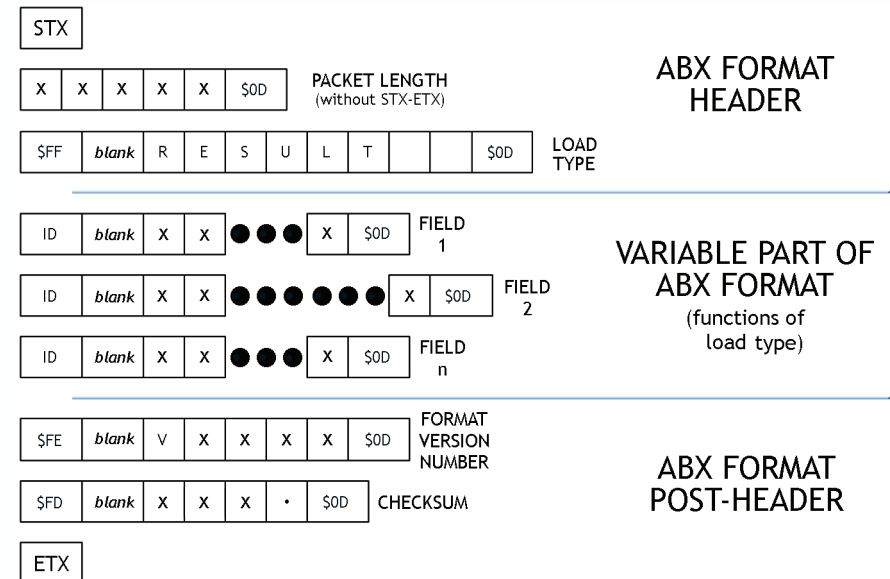

Diag.1: ABX format line structure

3.2. Control characters

Table 6: Standard control characters

Control String	Hexadecimal value
<ENQ>	\$05
<ACK>	\$06
<NAK>	\$15
<STX>	\$02
<ETX>	\$03

Table 6: Standard control characters

Control String	Hexadecimal value
<CR>	\$0D
<LF>	\$0A
<EOT>	\$04
<SOH>	\$01

4. Data transmitted by the host to the analyzer

Data packet files are available only if the instrument has been set up with the remote controlled mode.

"FILE" request:

The data packet "FILE" is followed by \$75 or \$76 representing the patient file to obtain the type of test to be run on the corresponding sample.

Table 7: Example of transmission between Host and Instrument

Flow	Dataflow	Comments
Instrument>Host	\$01	Pentra sends SOH
Host>Instrument	\$05	Host responds ENQ
Instrument>Host	\$02\$FF FILE \$0D \$75 123456789012 \$0D \$03	Pentra sends STX + First Query Message + ETX...
Host>Instrument	\$06	Host responds ACK
Instrument>Host	Pentra sends STX + Next Query Message + ETX
Host>Instrument	\$06	Host responds ACK
Instrument>Host	Pentra sends STX + Last Query Message + ETX
Host>Instrument	\$06	Host responds ACK
Instrument>Host	\$0200043\$0D \$FF END \$0D \$03	Pentra sends STX + Free line + ETX
Host>Instrument	\$06	Host responds ACK

Each data packet "FILE" is preceeded and followed by STX and ETX.

Several requests of this type can be chained between a line bid and a line free in order to organize the grouping of the requests for the instruments equipped with an automatic sampling mode.

Pentra 120DX / DF

Table 8: Data packet strings

Data packet string	Use
FILE	Patient file
END	Line free message

Patient identification:

- All the described fields have a fixed size character string type and are completed with blanks on the right side for the non-significant information.
- n= number
- c= character

Table 9: Identifier list (Host to Instrument)

Identifier	Correspondance	Example	Length	Format	Transmission	See Note
\$70 p	Analyzer number	01	2+2+1	Integers	required	
\$75 u	Id # or sample id.	1450302154275-42	2+16+1	String(16)	required	
\$76 v	Id. or patient name	SMITH Ronald	2+30+1	String(30)	required	
\$77 w	Birth date	YYYYMMDD	2+8+1	nnnnnnnn	optional	1
\$78 x	Age	7d or 4w or 10m or 54y or 100	2+3+1	String(3)	advised	2
\$79 y	Sex	0, 1 or 2	2+1+1	String(1)	advised	3
\$7A z	Origin	x	2+1+1	String(1)	optional	
\$7B {	Doctor	Dr Jones	2+15+1	String(15)	optional	
\$7C	Department	Cardiology	2+10+1	String(10)	optional	
\$7D }	Collection date	06/08/99 13h15	2+14+1	nn/nn/nn nnhnn	optional	
\$7E ~	Comments		2+32+1	String(32)	optional	
\$7F	Blood type	man	2+16+1	String(16)	optional	4

Table 9: Identifier list (Host to Instrument)

Identifier	Correspondance	Example	Length	Format	Transmission	See Note
\$80 ç	Analysis type	defined on 1 character (see description). 'A': analysis CBC 'B': analysis DIF 'C': analysis RET 'E': analysis CBR 'F': analysis DIR 'G': no analysis (smearing SPS only) 'H': ERB 'I': CBE 'J': CBF	2+1+1	String(1)	advised	5
\$89 ë	SPS smearing mode	ECC	2+3+1	String(3)	optional	6
\$8A è	SPS smearing profile	65G4	2+4+1	String(4)	optional	7
\$8B ï	Patient identification	200205125751	2+30+1	String(30)	advised	8



• NOTE 1 (\$77)

No check on \$77 compared to \$78.

• NOTE 2 (\$78)

\$78 is a 3 characters string completed on the right side by blanks. If age > 99 years, the 3 characters are used for the age without unit (ex: 102).

• NOTE 3 (\$79)

0 or Blank: Unspecified, 1: Male, 2: Female

• NOTE 4 (\$7F)

\$7F must be one of the instrument blood type list. If not, it is generated according to the age (\$78) or for adults according to the sex (\$79).

• NOTE 5 (\$80)

Table 10: Test compatibility

Instrument	CBC	DIFF	RET	CBR	DIR	ERB	CBE	CBF	SPS
Pentra DX	X	X	X	X	X	X	X		
Pentra DX + SPS	X	X	X	X	X	X	X		X
Pentra DF	X	X							
Pentra DF + SPS	X	X							X

• **NOTE 6 (\$89)**

First character is blank +3 characters ECC:

E: Smearing

C: Staining

C: Criteria

When the file is received without \$89, the default type is applied.

Table 11: ECC combinations

E	C	C	Action
E	C	C	A slide for Smearing and Staining is done before test. A slide could be done after test, according to instrument Reflex testing conditions
E	C	blank	A slide for Smearing and Staining is done before test. Reflex testing conditions are inhibited
E	blank	blank	A slide for Smearing is done before test. Reflex testing conditions are inhibited
E	blank	C	A slide for Smearing is done before test. A slide could be done after test, according to instrument Reflex testing conditions
blank	blank	C	No Slide Before test. A slide could be done after test, according to instrument Reflex testing conditions
blank	blank	blank	No Slide Before test. Reflex testing conditions are inhibited

• **NOTE 7 (\$8A)**

\$8A must be one of the Smearing profiles: drop volume, angle and speed.

• **NOTE 8 (\$8B)**

The Patient ID field can be transmitted, but it will be ignored by the instrument.

5. Data transmitted by the analyzer to the host

5.1. Packet type

The information described in the packet type allows the specification of the global message content: hematological routine results or statistic results.

Table 12: Packet type list

Data packet string (8 characters)	Use
RESULT	Hematological result transmission on a routine mode
RES-RR	Hematological result transmission on automatic re-sampling mode
RES-BLK	Hematological result transmission on blank cycle
QC-RES-H	Result transmission of a high level control blood
QC-RES-M	Result transmission of a median level control blood
QC-RES-L	Result transmission of a low level control blood
FILE	Patient file request
END	Connection end

5.2. Identifier list (Instrument to Host)

Table 13: Identifier list (Instrument to Host)

Identifier	Correspondance	Example	Length	Format	See Note
\$70 p	Analyzer number	01	2+2+1	Integers	
\$71 q	Analysis date and time	03/01/05 13h15mn31s	2+19+1	String(19)	
\$72 r	Analyzer run number	115 or 005CBC06	2+16+1	String(16)	
\$73 s	Analyzer sequence number	0128: analysis counter since instrument start	2+4+1	2+16+1	9

Pentra 120DX / DF

Table 13: Identifier list (Instrument to Host)

Identifier	Correspondance	Example	Length	Format	See Note
\$74 t	Sampling mode	M: manual (open tube) R: rack (close tube)	2+1+1	String(1)	
\$75 u	Id # or sample id.	1450302154275-42	2+16+1	String(16)	
\$76 v	Id. or patient name	SMITH Ronald	2+30+1	String(30)	
\$77 w	Birth date	16/03/72 or 03161972	2+8+1	nn/nn/nn or nnnnnnnn	10
\$78 x	Age	7d or 4w or 10m or 54y or 100	2+3+1	String(3)	10
\$79 y	Sex	0, 1 or 2	2+1+1	String(1)	11
\$7A z	Origin	x	2+1+1	String(1)	
\$7B {	Doctor	Dr Jones	2+15+1	String(15)	
\$7C	Department	Cardiology	2+10+1	String(10)	
\$7D }	Collection date	06/08/99 13h15	2+14+1	nn/nn/nn nnhnn	
\$7E ~	Comments		2+32+1	String(32)	
\$7F	Blood type	man	2+16+1	String(16)	12
\$80 ç	Analysis type	defined on 1 character (see description). 'A': analysis CBC 'B': analysis DIF 'C': analysis RET 'E': analysis CBR 'F': analysis DIR 'G': without analysis (smearing SPS only) 'H': ERB 'I': CBE	2+1+1	String(1)	

Table 13: Identifier list (Instrument to Host)

Identifier	Correspondance	Example	Length	Format	See Note
\$81 ü	Sample rack type	0: 10 positions 1: 15 positions 2: 32 positions	2+1+1	Integer	
\$82 é	Number of runs	0, 1, ...	2+1+1	Integer	
\$83 â	Operator code	Bob	2+3+1	String(3)	



• NOTE 9: (\$73)

Rack Mode: the sequence number indicates «number of runs on a rack + Rack test mode + Tube position» with number of runs from 0 to 9, Rack number from 01 to 99 (according to the Instrument settings), Test (CBC, DIF, RET, ERB, DIR, CBR or CBE), position from 01 to 10

Stat Mode: contains a single number on 4 digits. This number automatically increments on each new stat analysis.

• NOTE 10 (\$78)

\$78 is a 3 characters string completed on the right handside by «spaces». If age exceeded 99 years, the 3 characters of the string are used for the age without unit (example: 102).

• NOTE 11 (\$79)

0 or blank: Unspecified, 1: Male, 2: Female

• NOTE 12 (\$7F)

\$7F must be one of the instrument blood type list. If not, it will be generated according to the age (\$78) or for adults by the sex (\$79).

5.2.1. Numerical result fields

- Units are standard units.
- If one parameter cannot be calculated by the analyzer, the field is replaced with --.--

Pentra 120DX / DF

Parameter status:

Following the numerical field, a first digit gives the counting rejection status or the suspicion, a second one gives the parameter value status according to high and low normalities, to high and low extreme values and to the overloading capacities.

Table 14: Identifier First digit

First digit (letter)	Correspondance
R	Parameter rejected for a counting default
S	Suspicious parameter value
D	Value obtained by dilution
blank	No anomaly observed

Table 15: Identifier Second digit

Second digit (letter)	Correspondance
B (french) or L (other languages)	Parameter < to the lower extreme value
b (french) or l (other languages)	Parameter < to the low normal value
blank	Parameter normal value
h	Parameter > to the high normal value
H	Parameter > to the high extreme value
C	Platelet concentrate
O	Parameter exceeding the capacity

Example: 5.5 millions RBC with a counting error in the standard units:

\$32 \$20 \$30 \$35 \$2E \$35 \$30 \$52 \$68 \$0D or
«2 05.50Rh» + carriage return.

Table 16: CBC numerical result fields list

Identifier	Correspondance	Example	Format (Length)
\$21 !	WBC	07.40	2+String(7)+1
\$32 2	RBC	04.64	2+String(7)+1
\$33 3	Hgb	14.17	2+String(7)+1
\$34 4	Hct	43.95	2+String(7)+1
\$35 5	MCV	94.68	2+String(7)+1
\$36 6	MCH	30.53	2+String(7)+1
\$37 7	MCHC	32.24	2+String(7)+1
\$38 8	RDW	12.98	2+String(7)+1
\$40 @	PLT	00401	2+String(7)+1
\$41 A	MPV	07.94	2+String(7)+1
\$42 B	THT	0.318	2+String(7)+1
\$43 C	PDW	13.50	2+String(7)+1

Table 17: DIF numerical result fields list

Identifier	Correspondance	Example	Format (Length)
\$21 !	WBC	07.40	2+String(7)+1
\$22 "	Lymphocytes (#)	02.03	2+String(7)+1
\$23 #	Lymphocytes (%)	27.40	2+String(7)+1
\$24 \$	Monocytes (#)	00.70	2+String(7)+1
\$25 %	Monocytes (%)	09.40	2+String(7)+1
\$28 (Neutrophils (#)	04.51	2+String(7)+1
\$29)	Neutrophils (%)	60.90	2+String(7)+1
\$2A *	Eosinophils (#)	00.13	2+String(7)+1
\$2B +	Eosinophils (%)	01.70	2+String(7)+1
\$2C ,	Basophils (#)	00.04	2+String(7)+1

Pentra 120DX / DF

Table 17: DIF numerical result fields list

Identifier	Correspondance	Example	Format (Length)
\$2D -	Basophils (%)	00.60	2+String(7)+1
\$2E .	Atypical Lymphocytes (#)	00.11	2+String(7)+1
\$2F /	Atypical Lymphocytes (%)	01.49	2+String(7)+1
\$30 0	Large Immature Cells (#)	00.03	2+String(7)+1
\$31 1	Large Immature Cells (%)	00.43	2+String(7)+1
\$32 2	RBC	04.64	2+String(7)+1
\$33 3	Hgb	14.17	2+String(7)+1
\$34 4	Hct	43.95	2+String(7)+1
\$35 5	MCV	94.68	2+String(7)+1
\$36 6	MCH	30.53	2+String(7)+1
\$37 7	MCHC	32.24	2+String(7)+1
\$38 8	RDW	12.98	2+String(7)+1
\$40 @	PLT	00401	2+String(7)+1
\$41 A	MPV	07.94	2+String(7)+1
\$42 B	THT	0.318	2+String(7)+1
\$43 C	PDW	13.50	2+String(7)+1

Table 18: RET numerical result fields list

Identifier	Correspondance	Example	Format (Length)
\$32 2	RBC	04.64	2+String(7)+1
\$3B ;	Reticulocytes (#)	0656	2+String(7)+1
\$3C <	Reticulocytes (%)	01.41	2+String(7)+1
\$3D =	Reticulocytes Low (%)	80.34	2+String(7)+1
\$3E >	Reticulocytes Median (%)	14.96	2+String(7)+1
\$3F ?	Reticulocytes High (%)	04.90	2+String(7)+1
\$47 G	Retic Immatures	00.02	2+String(7)+1

Table 18: RET numerical result fields list

Identifier	Correspondance	Example	Format (Length)
\$48 H	Mean fluorescent index (%)	17.97	2+String(7)+1
\$49 I	Mean reticulocyte vol.	107.5	2+String(7)+1
\$4A J	Corrected ret. count (%)	01.38	2+String(7)+1
\$4C L	IRF	.0500	2+String(7)+1

Table 19: ERB numerical result fields list

Identifier	Correspondance	Example	Format (Length)
\$21 !	WBC	04.64	2+String(7)+1
\$BA	ERB%	07.20	2+String(7)+1
\$BB	ERB#	01.70	2+String(7)+1
\$BE	CWBC	24.30	2+String(7)+1

Table 20: CBR numerical result fields list

Identifier	Correspondance	Example	Format (Length)
\$21 !	WBC	07.40	2+String(7)+1
\$32 2	RBC	04.64	2+String(7)+1
\$33 3	Hgb	14.17	2+String(7)+1
\$34 4	Hct	43.95	2+String(7)+1
\$35 5	MCV	94.68	2+String(7)+1
\$36 6	MCH	30.53	2+String(7)+1
\$37 7	MCHC	32.24	2+String(7)+1
\$38 8	RDW	12.98	2+String(7)+1
\$3B ;	Reticulocytes (#)	.0656	2+String(7)+1
\$3C <	Reticulocytes (%)	01.41	2+String(7)+1

Pentra 120DX / DF

Table 20: CBR numerical result fields list

Identifier	Correspondance	Example	Format (Length)
\$3D =	Reticulocytes Low (%)	80.34	2+String(7)+1
\$3E >	Reticulocytes Median (%)	14.96	2+String(7)+1
\$3F ?	Reticulocytes High (%)	04.90	2+String(7)+1
\$40 @	PLT	00401	2+String(7)+1
\$41 A	MPV	07.94	2+String(7)+1
\$42 B	THT	0.318	2+String(7)+1
\$43 C	PDW	13.50	2+String(7)+1
\$47 G	Retic Immatures	00.02	2+String(7)+1
\$48 H	Mean fluorescent index (%)	17.97	2+String(7)+1
\$49 I	Mean reticulocyte vol.	107.5	2+String(7)+1
\$4A J	Corrected ret. count (%)	01.38	2+String(7)+1
\$4C L	IRF	.0500	2+String(7)+1

Table 21: CBE numerical result fields list

Identifier	Correspondance	Example	Format (Length)
\$21 !	WBC	07.40	2+String(7)+1
\$32 2	RBC	04.64	2+String(7)+1
\$33 3	Hgb	14.17	2+String(7)+1
\$34 4	Hct	43.95	2+String(7)+1
\$35 5	MCV	94.68	2+String(7)+1
\$36 6	MCH	30.53	2+String(7)+1
\$37 7	MCHC	32.24	2+String(7)+1
\$38 8	RDW	12.98	2+String(7)+1
\$40 @	PLT	00401	2+String(7)+1
\$41 A	MPV	07.94	2+String(7)+1

Table 21: CBE numerical result fields list

Identifier	Correspondance	Example	Format (Length)
\$42 B	THT	0.318	2+String(7)+1
\$43 C	PDW	13.50	2+String(7)+1
\$BA	ERB%	07.20	2+String(7)+1
\$BB	ERB#	01.70	2+String(7)+1
\$BE	CWBC	24.30	2+String(7)+1

Table 22: DIR numerical result fields list

Identifier	Correspondance	Example	Format (Length)
\$21 !	WBC	07.40	2+String(7)+1
\$22 "	Lymphocytes (#)	02.03	2+String(7)+1
\$23 #	Lymphocytes (%)	27.40	2+String(7)+1
\$24 \$	Monocytes (#)	00.70	2+String(7)+1
\$25 %	Monocytes (%)	09.40	2+String(7)+1
\$28 (Neutrophils (#)	04.51	2+String(7)+1
\$29)	Neutrophils (%)	60.90	2+String(7)+1
\$2A *	Eosinophils (#)	00.13	2+String(7)+1
\$2B +	Eosinophils (%)	01.70	2+String(7)+1
\$2C ,	Basophils (#)	00.04	2+String(7)+1
\$2D -	Basophils (%)	00.60	2+String(7)+1
\$2E .	Atypical Lymphocytes (#)	00.11	2+String(7)+1
\$2F /	Atypical Lymphocytes (%)	01.49	2+String(7)+1
\$30 0	Large Immature Cells (#)	00.03	2+String(7)+1
\$31 1	Large Immature Cells (%)	00.43	2+String(7)+1
\$B4 ´	IML (%)	000.5	2+String(7)+1
\$B5 µ	IML (#)	00.05	2+String(7)+1

Table 24: Identifier list (French)

Identifier	Parameter	Format	Length
\$50 P	GB ou LMG	L1 M1 M2 G1 G2 G3	2+12+1
\$51 Q	Formule	Co Mb Lg Ln Mn Ng Md Nd Bf Ne Bg Lg1	2+25+1
\$52 R	GR	MI MA (Mi Ma P80 V1.1)	2+4+1
\$53 S	Plaquettes	Pc Sc Mc	2+6+1
\$66 f	Balance GB	BASO ou GB-1 ou GB-2 et Lmne+ ou Lmne- et Baso+ ou Baso-	2+14+1
\$67 g	Générales	MpXbXr	2+6+1
\$68 h	Réticulocytes	LowLasPitFitNrbc	2+16+1
\$A2 I	RUOs	RUO message (See Note 13)	2+76+1



- **NOTE 13:**
«RUO message» is a warning message, transmitted always in english language. Its content and size depend on the instrument.

5.2.3. Pathology messages fields

Each pathology is described by a group of 4 characters followed by a blank, except for the last one.

The content of the pathology is dependent from the chosen language.

Only detected pathologies are transmitted. A common header (????) to the 4 Pathology message groups, indicates that the pathological interpretation is impossible.

Table 25: Identifier list

Identifier	Parameter	Format	Length
\$54 T	WBC	String of characters	1 + 12x5 + 1 (max)

Table 25: Identifier list

Identifier	Parameter	Format	Length
\$55 U	RBC	String of characters	1 + 7x5 + 1 (max)
\$56 V	PLT	String of characters	1 + 4x5 + 1 (max)
\$69 i	RET	String of characters	1 + 2x5 + 1 (max)

When there is no pathological message, length is: 2+0+1

Table 26: Pathological format description (English and other languages)

Population	Message	Signification
WBC	LEU+ or LEU-	Leukocytosis Leukopenia
	LYM+ or LYM-	Lymphocytosis Lymphopenia
	NEU+ or NEU-	Neutrophilia Neutropenia
	EOS+	Eosinophilia
	MYEL	Myelemia
	LIMC	Large Immature Cells
	ALYM	Atypic Lymphocytes
	LSHT	Left shift
	NRBC	Nucleated Red Blood Cells
	MON+	Monocytosis
RBC	BAS+	Basophilia
	BLST	Blasts
	ANEM	Anemia
	ANI1 or ANI2 or ANI3	Anisocytosis level 1 Anisocytosis level 2 Anisocytosis level 3

Pentra 120DX / DF

Table 26: Pathological format description (English and other languages)

Population	Message	Signification
	MIC1 or MIC2 or MIC3	Microcytes level 1 Microcytes level 2 Microcytes level 3
	MAC1 or MAC2 or MAC3	Macrocytes level 1 Macrocytes level 2 Macrocytes level 3
	MICR	Microcytosis
	MACR	Macrocytosis
	HCR1 or HCR2 or HCR3	Hypochromia level 1 Hypochromia level 2 Hypochromia level 3
	CAGG	Cold agglutinin
	ERYT	Erythrocytosis
Plt	THR+	Thrombocytosis
	THR-	Thrombopenia
	PLAG	Platelet aggregates
	SCEL	Small cells
	MICC	Microcytes
	SCHI	Schizocytes
	MAPL	Macro platelet
Reticulocytes	IMMT	Immature reticulocytes
	RET+ or RET-	Reticulocytosis Reticulopenia
All populations	????	No interpretation
	PANC	Pancytopenia

Table 27: Pathological format description (French)

Population	Messages	Signification
GB	LEU+ or LEU-	Leucocytose Leucopénie
	LYM+ or LYM-	Lymphocytose Lymphopénie
	NEU+ or NEU-	Neutrophilie Neutropénie
	EOS+	Eosinophilie
	MYEL	Myélocémie
	GCIM	Grandes Cellules Immatures
	LYAT	Lymphocytes atypiques
	FORG	Formule gauche
	MON+	Monocytose
	BAS+	Basophilie
	BLST	Blastes
GR	ANEM	Anémie
	ANI1 or ANI2 or ANI3	Anisocytose niveau 1 Anisocytose niveau 2 Anisocytose niveau 3
	MIC1 or MIC2 or MIC3	Microcytes niveau 1 Microcytes niveau 2 Microcytes niveau 3
	MAC1 or MAC2 or MAC3	Macrocytes niveau 1 Macrocytes niveau 2 Macrocytes niveau 3
	MICR	Microcytose
	MACR	Macrocytose

Pentra 120DX / DF

Table 27: Pathological format description (French)

Population	Messages	Signification
	HCR1 or HCR2 or HCR3	Hypochromie niveau 1 Hypochromie niveau 2 Hypochromie niveau 3
	AGGF	Agglutinine froide
	POLY	Erythrocytose
Pla	THR+	Thrombocytose
	THR-	Thrombopenie
	AGPL	Agrégats plaquettaires
	PECL	Petits éléments cellulaires
	MICC	Microcytes
	SCHI	Schizocytes
	MAPL	Macro plaquettes
Réticulocytes	IMMT	Réticulocytes immatures
	RET+ or RET-	Réticulocytose Réticulopénie
Toutes populations	????	Pas d'interprétation possible
	PANC	Pancytopenie

5.2.4. Histograms

5.2.4.1. Histograms

Histograms are transmitted on 128 channels, preceded by a blank. They are automatically rescaled to a 223 maximum amplitude value. The zero amplitude value is \$20, the maximum amplitude value is \$FF.

Extended format:

The extended format includes all the height information relative to each channel. It is constituted by a chart of 256 [RES] entries of 16 bits each.

These 512 bytes chart is encoded before being transmitted. The format is as follows: identifier, space, encoding type on 8 characters (od or uuencode), space, encoded data size on 5 characters, space, data then carriage return.

5.2.4.2. Separation thresholds

It is the channel number (decimal value) enclosing areas on the histograms or on the matrix. Each threshold is transmitted on 3 bytes preceded by a blank.

5.2.4.3. Format description of the threshold transmission

A. WBC thresholds

Separation thresholds 1-2-3 allow the L1 flag determination. For the analyzers in LMG mode, the 4-5 thresholds allow the separation of the 3 populations Lymphocytes, Monocytes, Granulocytes.

Example 1: output format of the WBC curve thresholds for an LMG sampling. In this example, the analyzer does not send the calculation thresholds of the L1 flag.

«] 000 000 000 040 060» + carriage return.

Example 2: output format of the WBC curve thresholds for CBC and DIFF sampling. In this 5parts DIFF analyzer, the LMG is not measured, the 4-5 thresholds are not significant.

«] 005 008 020 000 000» + carriage return.

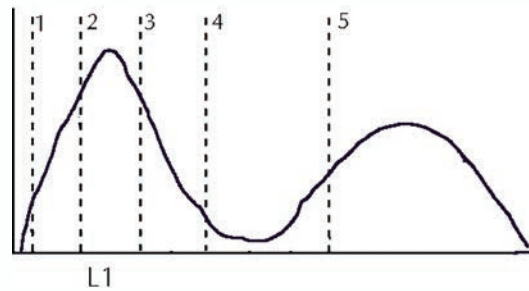

Diag.2: WBC histogram

B. RBC thresholds

Separation thresholds 1-2 allow the calculation of the microcytic and macrocytic cell proportions.

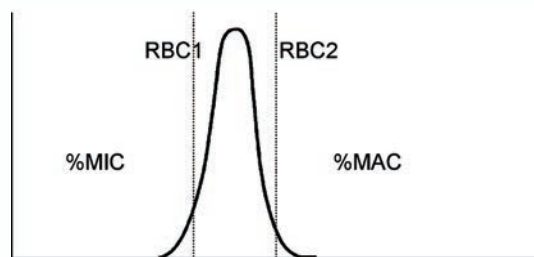

Diag.3: RBC histogram

C. PLT thresholds

The threshold 1 is the number of the last channel used to calculate the PLT number.

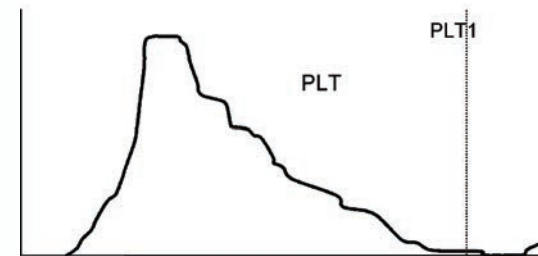

Diag.4: Plt histogram

D. Basophil thresholds

Thresholds 1-2-3 allow the determination of the basophil proportion regarding the total number of WBCs.

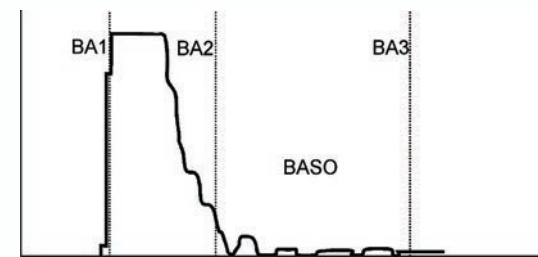

Diag.5: BASO histogram

Table 28: Histogram format description

Identifier	Parameter	Format	Length
\$57 W	WBC	Amplitude of each channel	2+128+1
\$58 X	RBC	Amplitude of each channel	2+128+1
\$59 Y	Plt	Amplitude of each channel	2+128+1

Table 28: Histogram format description

Identifier	Parameter	Format	Length
\$5A Z	Basophils	Amplitude of each channel	2+128+1
\$5D]	WBC thresholds	5 thresholds	1+20+1
\$5E ^	RBC thresholds	2 thresholds	1+8+1
\$5F _	PLT thresholds	1 threshold	1+4+1
\$60 '	Basophil thresholds	3 thresholds	1+12+1

5.2.5. Matrix principles

A. ERB-RETIC Matrix principles

Screen bitmap: 2048 graphic bytes matrix are transmitted on 4096 ASCII bytes, preceded by a space. Each group of 2 ASCII bytes is the value of 1 graphic byte represented from the left to the right and from the top to the bottom of the screen. The matrix ERB-RET [128(ABS) x 128(RES)] is transmitted according to the same process.

B. LMNE matrix principles

Screen bitmap: 4096 graphic bytes matrix are transmitted on 8192 ASCII bytes, preceded by a space. Each group of 2 ASCII bytes is the value of 1 graphic byte represented from the left to the right and from the top to the bottom of the screen. The double matrix Lmne [128(ABS) x 256(RES)] is transmitted according to the same process.

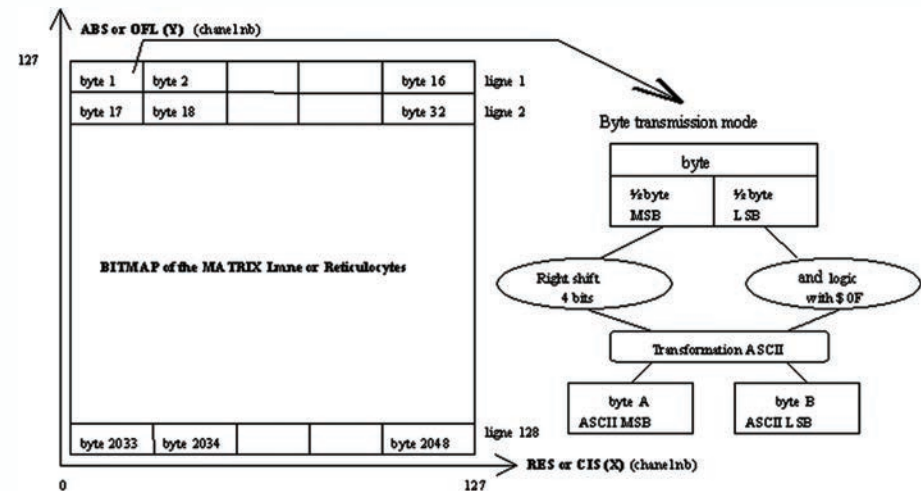

Diag.6: Matrix transmission

5.2.6. Matrix thresholds

A. Reticulocyte matrix thresholds

The 4 resistive thresholds are transmitted in the following order: R1, R2, R3, R4. Then the 4 fluorescent thresholds are following: F1, F2, F3, F4.

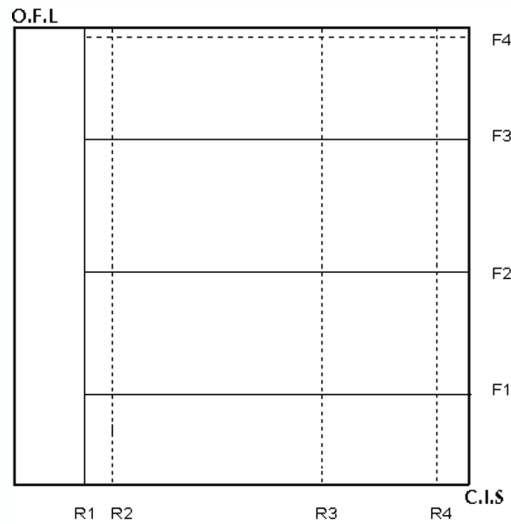

Diag.7: Reticulocytes matrix thresholds

B. ERB matrix thresholds

The 3 CIS thresholds are transmitted in the following order: R1, R2, R3. Then the 3 OFL thresholds are following: F1, F2, F3.

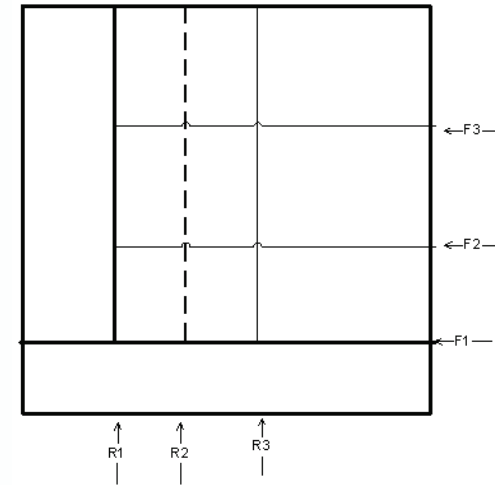

Diag.8: ERB matrix thresholds

C. LMNE matrix thresholds

The 12 resistive thresholds are transmitted in the following order: BFL, BFN, BFE, NG, ND, LG, LYA, LMN, LI, MI, MDI, IGI.

The 11 absorbance thresholds are transmitted in the following order: NL, NE, MND, LMI, MMD, IB, IH, IGIB, IGIH, GIB, GIH.

The width of the areas (002 channels) describing the proximity thresholds (ANE, AMN, ALN) are also transmitted.

Table 29: Channel Numbers for Resistive Thresholds

Thresholds	BFL	BFN	BFE	NG	ND	LG	LYA	LMN	LI	MI	MDI	IGI
Channel numbers	022	025	048	037	100	030	067	068	088	127	145	190

Table 30: Channel Numbers for Absorbance Thresholds

Thresholds	NL	NE	MND	LMI	MMD	IB	IH	IGIB	IGIH	GIB	GIH
Channel numbers	031	069	050	021	026	028	055	031	070	037	095

Table 31: Histogram & Matrix format description

Identifier	Parameter	Format	Length
\$5C \	Reticulocyte matrix	Screen bitmap	2+4096+1
\$C6 Æ	ERB matrix	Screen bitmap	2+4096+1
\$63 c	Double matrix Lmne	screen bitmap	2+8192+1
\$C8 È	Lmne matrix thresholds	12 RES thresholds /11 ABS thresholds 3 proximity thresholds	1+104+1
\$62 b	Reticulocyte matrix thresholds	4 CIS thresholds, 4 OFL thresholds	1+32+1
\$C9 É	ERB matrix thresholds	3 CIS thresholds, 3 OFL thresholds	1+24+1

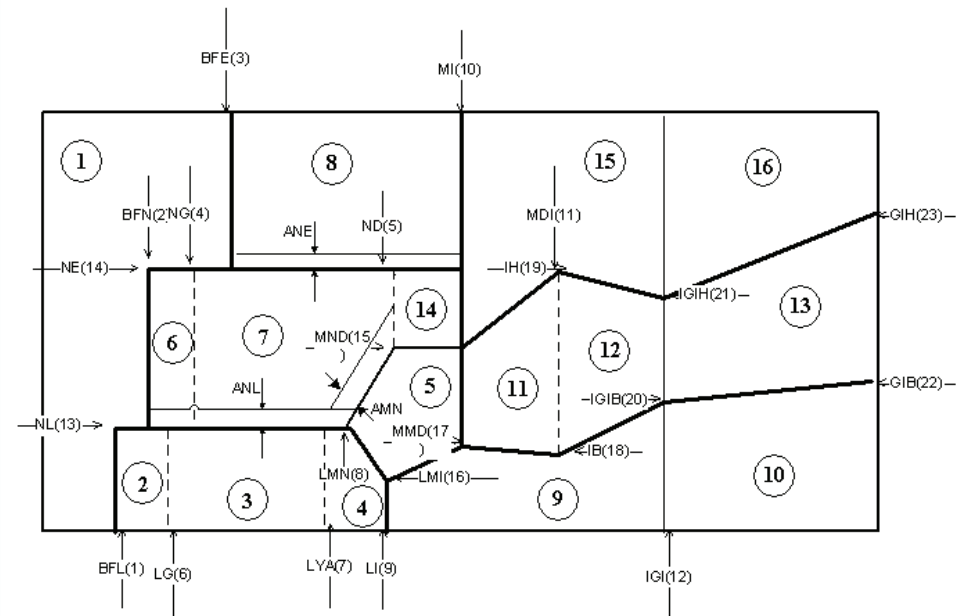

Diag.9: Lmne matrix thresholds

5.2.7. Other identifiers

Identifier \$FB: Identifies the analyzer type when communicating.

Identifier \$FC: This identifier allows the transmission of a number which can be an error number, a position number, a burn-in sequence number or a status in hexadecimal mode (Not available yet).

Identifier \$FD: Checksum value (see section on the message structure).

Identifier \$FE: The version number is linked to the development of the hematological message identifiers.



Identifier \$FC: The error list is dedicated to the "remote" mode. For \$FB and \$FF, the strings having less than 8 characters are completed on the right side by blanks.

Table 32: Other identifiers

Identifier	Correspondance	Format	Length
\$FB	Analyzer name	Character string	2+8+1
\$FC	Number	8 decimal bytes	2+8+1
\$FD	16 bits check sum value	4 hexadecimal bytes	2+4+1
\$FE	Version N° of Identifier list	String of characters: Vx.xx	2+5+1

6. Query mode

6.1. Sending orders

Requests sent by the host when the line is free.

Query mode:

- This optional mode allows the Host to selectively load the working list of each sample, once the barcode of the sample is read and a Query request is emitted by the instrument.
- This mode is of particular interest when the Host system manages several instruments analysers. In this case, the Query request transmitted by one of the analysers allows the Host system to load the working list on the instrument identified by the presence of the sample on this analyzer.
- The Query request is a 'FILE' type message and encapsulates 1 or several blocks surrounded by STX & ETX including the '\$75' type line followed by the identification of the sample (barcodes) (Maximum 10 Blocks per Query request).
- Transmission of the Query requests is carried out by instrument immediately after the tray of 10 samples is read. Only the samples identified by a barcode, and for which instrument did not receive a working list are transmitted in the QUERY request.
- The Host system has an answering delay which is adjustable on the analyzer (25 seconds by default). This delay is fixed after transmission of the last Query message, in order to return the message to load the working list of the sample or the samples concerned. Once the delay has been respected and in the case where no message is received by the analyzer, the rack of samples is automatically discharged without carrying out tests.
- The adjustment of the answering delay of the Host system is ideally fixed at 25 seconds by default. It is possible to change the value of this parameter, however, from 30 seconds on the analyser generates a supplementary waiting cycle of 30 seconds, or 2 waiting cycles from 60 seconds, involving a reduction of the analytical output capacity.

Table 33: QUERY request line structure

Identifier	Correspondance	Format	Length
\$FF ÿ	Data Packet	Character string	2+8+1
\$75 u	Identification #	Character string	2+16+1

Loading protocol of a working list in answer to a QUERY request:

Table 34: Instrument transmits to the Host a QUERY request

Flow	Dataflow	Comments
Instrument>Host	\$01	Pentra sends SOH
Host>Instrument	\$05	Host responds ENQ
Instrument>Host	\$02\$FF FILE \$OD \$75 123456789012 \$OD \$03	Pentra sends STX + First Query Message + ETX
Host>Instrument	\$06	Host responds ACK
Instrument>Host	Pentra sends STX + Next Query Message + ETX
Host>Instrument	\$06	Host responds ACK
Instrument>Host	Pentra sends STX + Last Query Message + ETX
Host>Instrument	\$06	Host responds ACK
Instrument>Host	\$02 00043\$OD \$FF END \$OD \$03	Pentra sends STX + Free line + ETX
Host>Instrument	\$06	Host responds ACK

Once the Host receives a Query type message, it returns a message to load the working list for the sample or samples concerned, respecting the delay programmed on the instrument (25 seconds by default).

6.2. Resampling and reflex testing

- This optional mode offers the possibility to the Host system of returning the re-sampling request to the analyser, according to a decision algorithm calculated by the Host system and in answer to an analytical result transmitted by the analyser.
- The request of re-sampling allows for the carrying out of the same tests as those requested during the former sampling procedure, or any other test amongst those available. It is therefore possible for example to carry out a request for complementary tests during the re-sampling procedure.
- When the remote controlled re-sampling mode is activated and after transmission of each result the analyser waits for the re-sampling decision message from the Host system. Whatever decision is taken by the Host system, it returns a message, either a re-sampling request, or when the result obtained does not require re-sampling the freeing of the blood sample without re-sampling.
- The Host system has an answering delay which is adjustable on the analyser (25 seconds by default). This delay is fixed after transmission of the last result in order to return the re-sampling request or the message to free the sample. Once the delay has been respected and in the case where no message is received by the analyser, the rack of samples is automatically discharged without re-sampling .
- The adjustment of the answering delay of the Host system is ideally fixed at 25 seconds by default. It is possible to change the value of this parameter, however, from 30 seconds on the analyser generates a supplementary waiting cycle of 30 seconds, or 2 waiting cycles from 60 seconds involving consequently a reduction of the analytical output capacity.

Pentra 120DX / DF

Table 35: Structure of lines included in the message «re-sampling request»

Identifier	Correspondance	Format	Length
\$FF ÿ	Data Packet	Character string	2+8+1
\$75 u	Identification	Character string	2+16+1
\$80 Ç	Analysis type	Defined on 1 character (See Note 5)	2+1+1

Table 36: Structure of lines included in the message «end of re-sampling»

Identifier	Correspondance	Format	Length
\$FF ÿ	Data Packet	Character string	2+8+1
\$75 u	Identification	Character string	2+16+1
\$80 Ç	Analysis type	'@'	2+1+1

Table 37: Transmission of results protocol and insertion of automatic re-sampling

Flow	Dataflow	Comments
Instrument>Host	\$01	Pentra sends SOH
Host>Instrument	\$05	Host responds ENQ
Instrument>Host	\$0205395\$OD \$FF RESULT \$OD \$03	Pentra sends STX + Result + ETX

Table 37: Transmission of results protocol and insertion of automatic re-sampling

Flow	Dataflow	Comments
Host>Instrument	\$06	Host responds ACK
Instrument>Host	\$02 00043\$OD \$FF END \$OD \$03	Pentra sends STX + Free line + ETX
Host>Instrument	\$06	Host responds ACK

Once the line is free the Host returns a re-sampling message in a delay of <25s ideally.

Table 38: Host sends «re-sampling message»

Flow	Dataflow	Comments
Host>Instrument	\$01	Host sends SOH
Instrument>Host	\$05	Pentra responds ENQ
Host>Instrument	\$02\$FF FILE \$OD \$75 123456789012 \$80 B \$OD \$03	Host sends STX + ReRun + ETX
Instrument>Host	\$06	Pentra responds ACK
Host>Instrument	\$02 00043\$OD \$FF END \$OD \$03	Host sends STX + Free line + ETX
Instrument>Host	\$06	Pentra responds ACK

...or the Host returns a message «end of re-sampling»

Pentra 120DX / DF

Table 39: Host sends «end of re-sampling»

Flow	Dataflow	Comments
Host>Instrument	\$01	Host sends SOH
Instrument>Host	\$05	Pentra responds ENQ
Host>Instrument	\$02\$FF FILE \$OD \$75 123456789012 \$80 @ \$OD \$03	Host sends STX + No more RerRun + ETX
Instrument>Host	\$06	Pentra responds ACK
Host>Instrument	\$02 00043\$OD \$FF END \$OD \$03	Host sends STX + Free line + ETX
Instrument>Host	\$06	Pentra responds ACK