

## OUTPUT FORMATS

Pentra  200  
RAA044BEN

## Table of Contents

1. Introduction .....	3	3.11. S: Scientific Record .....	23
1.1. System configuration .....	3	3.12. M: Manufacturer Information Record .....	24
2. Low level control .....	4	4. Communication sequence .....	25
2.1. Physical Layer .....	4	4.1. Communication Modes .....	25
2.1.1. Communication specifications .....	4	5. Communication Sequence .....	27
2.1.2. Connectors .....	4	5.1. Confirmation of Connection Sequence .....	27
2.1.3. Pin assignment .....	4	5.1.1. Connection confirmation at beginning of each round (On-Line Batch mode/ Real-time mode) .....	27
2.1.4. Interface signals .....	4	5.2. Batch Sequence .....	28
2.1.5. Cable specifications .....	5	5.2.1. Batch transmission of result to Host .....	28
2.2. Data Link Layer .....	5	5.2.2. Inquiry to Host for order and response .....	29
2.2.1. Summary of transmission control characters .....	5	5.3. Real-time Sequence .....	31
2.2.2. Message composition .....	5	5.3.1. Real-time inquiry to Host for one sample and its response .....	31
2.2.3. Transmission procedure .....	6	5.3.2. Real-time transmission of result to Host for one sample .....	32
2.2.4. Status transition table .....	7	6. Error Handling .....	33
3. High level control .....	9	6.1. Transmission error .....	33
3.1. Command Record.....	9	6.2. Reception Error.....	35
3.2. Data Character Code .....	9	6.2.1. Error during batch order inquiry and its response .....	35
3.3. Sequence Number .....	9	6.2.2. Error during test order inquiry for a sample at real-time mode .....	36
3.4. H: Message Header Record.....	11	6.3. Abnormal data .....	38
3.5. P: Patient Information Record.....	12	6.3.1. Sequence Number .....	38
3.6. O: Test Order Record.....	14	6.3.2. Abnormal data .....	38
3.7. R: Result Record.....	17	6.4. Retry over .....	38
3.7.1. Test result error flag code .....	18	7. Annex: Method Numbers table .....	39
3.8. C: Comment Record .....	21		
3.9. Q: Request Information Record .....	22		
3.10. L: Message Terminator Record .....	23		



## 1. Introduction

This document specifies the communication scheme between the Pentra C200 (hereinafter called Analyzer) and the Host Computer (hereinafter called Host). The construction of this on-line system enables communication between the Analyzer and the Host, and retrieval of the measurement results from the Analyzer in response to an external order. This on-line system defines each item as a protocol within the conformity of the following standards:

- Lower level (Low level control): ASTM E1381-95
- High level (High level control): ASTM E1394-91

### 1.1. System configuration

The communication between the Analyzer and the external Host is conducted with the RS232C interface. The interconnection between them is shown below:

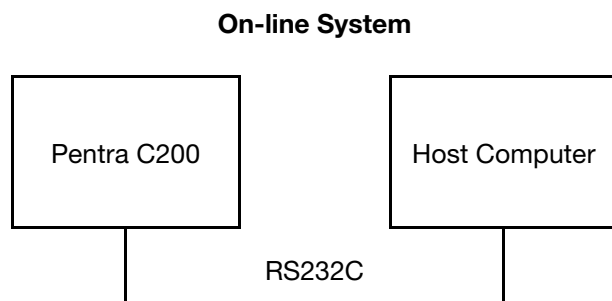

*Diag.1: Interconnection between Analyser and Host*

## 2. Low level control

The specifications of connectors, cables, protocol, etc. which are necessary for exchange of messages between Host and Analyzer, are given in the following sub-clauses.

### 2.1. Physical Layer

#### 2.1.1. Communication specifications

Item	Specifications	Default value
1 Transmission mode	Synchronous RS232C start-stop transmission Half-duplex	
2 Transmission rate	300 / 1200 / 2400 / 4800 / 9600 / 19200	9600bps
3 Transmission code	ASCII	
4 Date length	7 bits / 8 bits	8 bits
5 Parity	Odd / even / none	Even parity
6 Start bit	1 bit / 2 bits	1 bit

#### 2.1.2. Connectors

Connector on the Analyzer is a D-sub 9pin Male.  
Connector at the Analyzer side of cable is a D-sub 9pin Female.

#### 2.1.3. Pin assignment

Pin number	Signal designation
1	CD
2	RD
3	TD
4	DTR
5	GND
6	DSR
7	RTS
8	CTS
9	RI

#### 2.1.4. Interface signals

Functions of interface signals

Abbreviation	Signal designation	Function
CD	Carrier Detect	Not monitored
RD	Receive Data	Pin for data reception
TD	Transmit Data	Pin for data transmission
DTR	Data Terminal Ready	Set to ON when Host communication is ready.
GND	Signal Ground	-
DSR	Data Set Ready	Monitor the Host. When this is OFF, the counterpart may be disconnected or turned off. Available for data transmission.
RTS	Request To Send	Set to ON while data reception is available. Set to OFF when the data buffer is full and cannot receive data.
CTS	Clear To Send	Wait data transmission till this becomes ON.
RI	Ring Indicator	Not monitored



### 2.1.5. Cable specifications

The cable for Host communication is RS232C with one of the two following cable connections depending on the handling of interface signals of the Host.

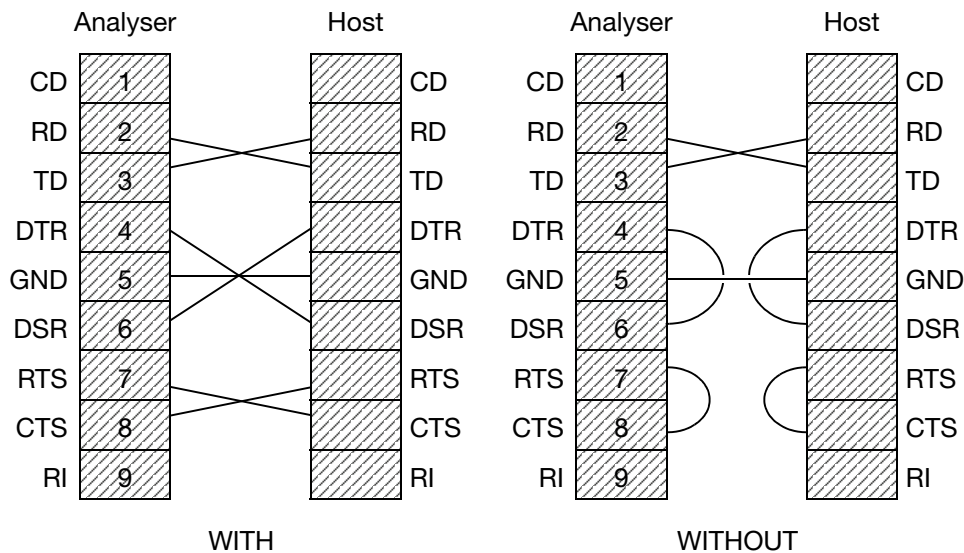

Diag.2: Cable connection WITH or WITHOUT handling of interface signals

## 2.2. Data Link Layer

The information necessary to ensure the exchange of messages between Host and Analyzer is shown in the following sub-clauses.

### 2.2.1. Summary of transmission control characters

Designation	Meanings	ASCII code	Remarks
ENQ	Acknowledge	05H	Request for transmission
EOT	End of Transmission	04H	Link opening
ACK	Acknowledge	06H	Positive acknowledgement
NAK	Negative Acknowledge	15H	Negative acknowledgement
STX	Start of Text	02H	Start of text
ETX	End of Text	03H	End of text in the final frame
ETB	End of Transmission Block	17H	End of text in the intermediate frame

### 2.2.2. Message composition

Field #	1)	2)	...	...	...	...	...	n-1)	n)
Item	STX	FN	TEXT	CR	ETX	C1	C2	CR	LF

(n ≤ 247)

Field #	Item	Data length	Description
1)	STX	1	To indicate the start of frame (ASCII code: 02H)
2)	FN	1	Sequence number of frame (0 - 7) (NOTE 1)
3)	TEXT	239	Text (NOTE 2)
4)	CR	1	(ASCII code: 0DH)
5)	ETX	1	To indicate the end of frame (ASCII code: 03H) (NOTE 3)
6)	C1	1	The upper digit of checksum (NOTE 4)



Field #	Item	Data length	Description
7)	C2	1	The lower digit of checksum
8)	CR	1	(ASCII code: 0DH)
9)	LF	1	(ASCII code: 0AH)



- NOTE 1: FN is the sequence number assigned to each frame and the ASCII text (0, 1, 2, 3, 4, 5, 6 and 7) is cyclically used. At reception of message with same sequence number, handle as duplicate of re-transmission and discard the message. Messages divided with ETB will have new sequence number. Initial value shall be "1".
- NOTE 2: TEXT is the division of ASCII text message itself and the number of characters for one text is limited to less than 240 characters (including "CR") and below. Addition of "CR" is optional setting. It is possible to set from details setting on System Settings.
- NOTE 3: ETX code (ASCII code: 03H) or ETB code (ASCII code: 17H).
- NOTE 4: In the checksum (Hex) frame, calculate the sum of bits of each message from FN to ETX excluding STX and use last two digits. When checksum do not match, discard the message.

Where the text exceeds 240 bytes, it can be divided with ETB (ASCII code: 17H).

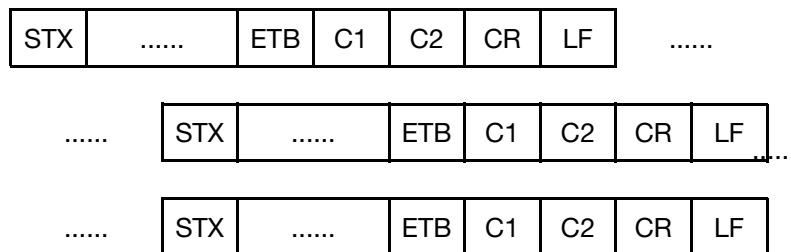

Diag.3: Text divided with ETB

### 2.2.3. Transmission procedure

Transmission of data from Analyzer to Host.  
The control codes are shown in < > in the following figure.

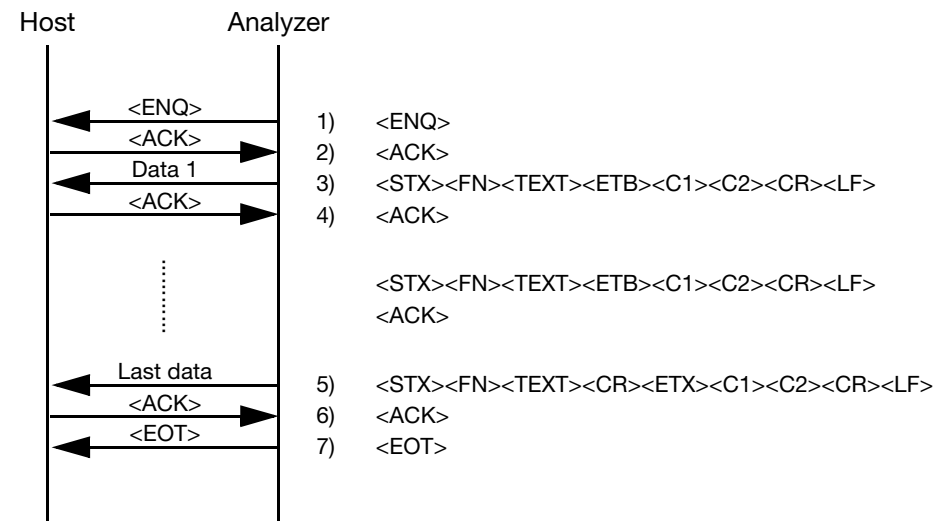

Diag.4: Transmission of data from Analyzer to Host.

- 1) Analyzer transmits <ENQ> in order to establish a data link.
- 2) <ACK> is sent from Host after it is ready for communication.
- 3) Data 1 (intermediate frame) <ETB>
- 4) When Host has received the data correctly, <ACK> is sent to the Analyzer.
- 5) End of data (last frame) <ETX>
- 6) Link is opened.



**2.2.4. Status transition table**

Status	Sending data exist	No sending data	ENQ reception	ETX, ETB reception	EOT reception	ACK reception
Initialization	Send ENQ Start T1 timer Status to "Establishing connection"	No action	Send ACK Start T3 timer Status to "Data reception"	No action	No action	No action
Establishing connection	No action	No action	Stop T1 timer Wait 1 sec. Send ENQ Start T1 timer	No action	No action	Stop T1 timer Send data Start T2 timer Status to "Waiting response"
Connected	Send data Start T2 timer Status to "Waiting response"	Send EOT Status to "Initialization"	No action	No action	No action	No action
Waiting response	No action	No action	No action	No action	Stop T2 timer Send EOT Start T4 timer Status to "Initialization-2"	Stop T2 timer Status to "Establishing connection"
Data reception	No action	No action	No action	Restart T3 timer Status to "Completing data reception"	Stop T3 timer Status to "Initialization"	No action
Completing data reception	No action	No action	No action	No action	Stop T3 timer Status to "Initialization"	No action
Initialization-2	No action	No action	Stop T4 timer Send ACK Start T3 timer Status to "Data reception"	No action	No action	No action



Status	NAK reception	Data reception	Timer timeout T1: 15 sec	Send data timeout T2: 15 sec	Data reception timeout T3: 30 sec	Data reception interruption timeout T4: 15 sec
Initialization	No action	No action	No action	No action	No action	No action
Establishing connection	Send ENQ Restart T1 timer	No action	Stop T1 timer Send EOT Status to "Initialization"	No action	No action	No action
Connected	No action	No action	No action	No action	No action	No action
Waiting response	Send data again Restart T2 timer	No action	No action	Stop T2 timer Send EOT Return data Status to "Initialization"	No action	No action
Data reception	No action	Restart T3 timer Data reception Send ACK/NAK	No action	No action	Stop T3 timer Discard corrupted received data Status to "Initialization"	No action
Completing data reception	No action	No action	No action	No action	Stop T3 timer Discard corrupted received data Status to "Initialization"	No action
Initialization-2	No action	No action	No action	No action	No action	Stop T4 timer Status to "Initialization"



- NOTE 1: Wait timer between characters are 100ms. At time out, the action will be the same as receiving NAK.
- NOTE 2: At data re-transmission, sequence number should be the same as original data transmission.
- NOTE 3: At data reception, characters before STX and after ETB and ETX should be discarded.
- NOTE 4: All received data without sequential sequence number should be discarded.
- NOTE 5: Maximum retry of data re-transmission is five times. After the fifth retry, EOT will be sent and change status to Initialization. Error must be displayed in this condition.
- NOTE 6: Host should return status to Initialization after no connection for 20 seconds from the Analyser.
- NOTE 7: Maximum retry for ENQ is ten. After the tenth retry, generate an error then start over.



### 3. High level control

#### 3.1. Command Record

Following table defines usage of the command record types.

Type	Function name	Level	Transmission	Reception
1	H Message Header Record	0	Used	Used
2	P Patient Information Record	1	Used	Used
3	O Test Order Record	2	Used	Used
4	R Results Record	3	Used	Used
5	C Comment Record	-	Used	Used
6	Q Request Information Record	-	Used	Not used
7	L Message Terminator Record	0	Used	Used
8	S Scientific Record	1	Not used	Not used
9	M Manufacturer Information Record	-	Not used	Not used



Level: 0 (Higher) > 3 (Lower)

#### 3.2. Data Character Code

Following table defines availability of the characters.

Code (Decimal system)	
0 - 31	7, 9, 11, 12, 13 can be used.
13	Reserved as record terminator
32 - 126 128 - 254	Allowed
127, 255	Not allowed



When double quotation (ASCII 34) is found, discard it (do not treat as data).

#### 3.3. Sequence Number

The sequence number shall be generated for every message. Initial value shall be "1". Every transmission increment the number by "1". The number will set back to "1" at transmission of separate command with same level or command with higher level.

Sequence Number is generated by command type (H, P, and O).

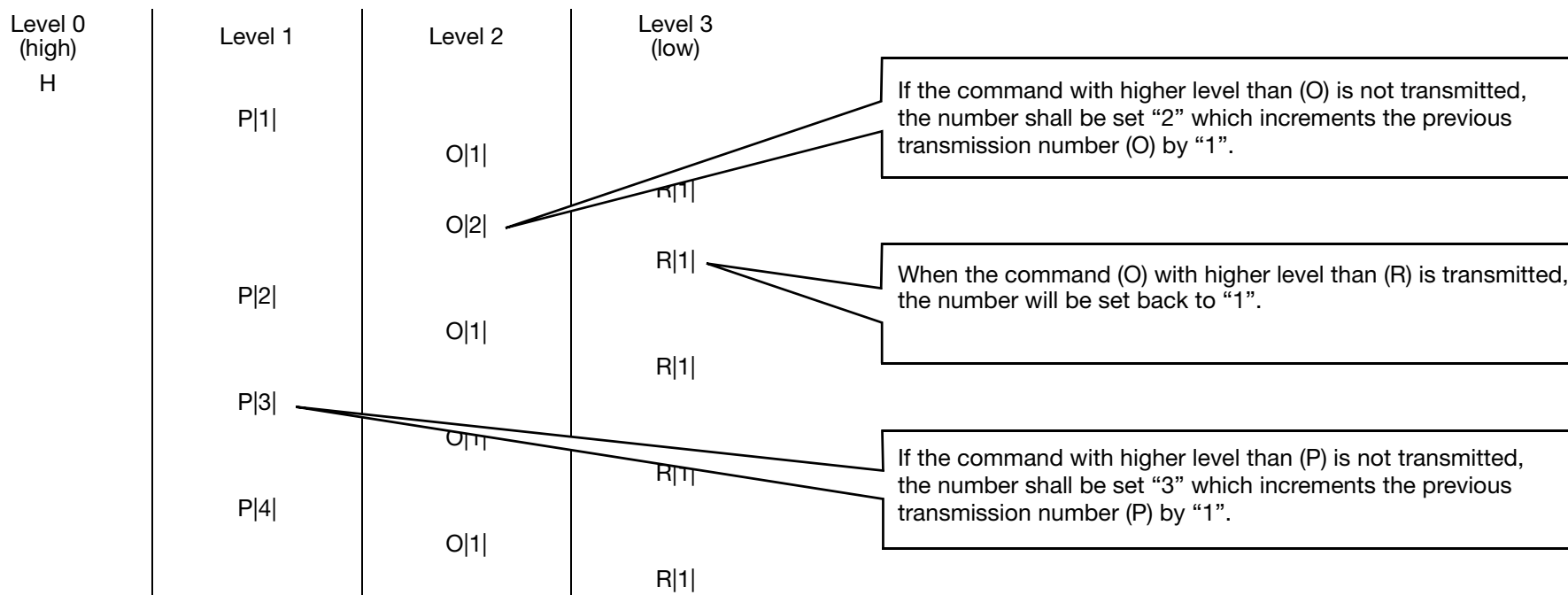

### 3.4. H: Message Header Record

The string specifies the Analyzer and Host between which messages are exchanged. This also specifies each delimiter character for field, repeat, component and escape delimiters.

Field #	Designation	Max. digits	Process upon reception from Host	This system used/unused	Omission	Process on transmission from Analyzer
1)	Record type	1	Abandoned	used	disapproved	Record type "H"
2)	Delimiter	4	Abandoned	used	disapproved	Delimiters established in this system ( , back slash, ^ and &)
3)	Message control ID	0	-	unused	-	-
4)	Access password	0	-	unused	-	-
5)	Name of Analyzer	32	Abandoned	used	disapproved	Name of Analyzer defined in this system
6)	Address of sender	0	-	unused	-	-
7)	Reserved field	0	-	unused	-	-
8)	Telephone number of sender	0	-	unused	-	-
9)	Characteristic of sender	0	-	unused	-	-
10)	Recipient ID	0	-	unused	-	-
11)	Note or special instruction	0	-	unused	-	-
12)	Process ID	0	-	unused	-	-
13)	Version No.	0	-	unused	-	-
14)	Date & time	14	Abandoned	used	disapproved	Date and time at transmission. YYYYMMDDHHMMSS



**Meanings of "used/unused":**

- used: data available at transmit side;
- unused: no data at transmit side.

**Meanings of "Omission":**

- disapproved: omission is not approved;
- approved: omission is approved.
- : The item is not used in this system and thus must be omitted.



### 3.5. P: Patient Information Record

The string is sent from Host to Analyser at ordering test requests. This is also sent from Analyser to Host when sending test results which as specified by Host.

Field #	Designation	Max. digits	Process upon reception from Host	This system used/unused	Omission	Process on transmission from Analyzer
1)	Record type	1	Abandoned	used	disapproved	Record type "P"
2)	Sequence number	6	Abandoned	used	disapproved	Refer to 3.3. <a href="#">Sequence Number</a> , page 9.
3)	Patient ID	13	Used for transmission, display and print.	used	disapproved	Send as received
4)	Laboratory assigned Patient ID	0	-	unused	-	-
5)	Patient ID #3	0	-	unused	-	-
6)	Patient Name	36	Used for transmission, display and print. Max. Characters; Last name 12 First name 12 Middle name 12 Use "^" for delimiter	used	approved	Send as received
7)	Mother's Maiden Name	0	-	unused	-	-
8)	Date of Birth	8	Used for transmission, display and print. YYYYMMDD	used	approved (NOTE 1)	Send as received
9)	Sex	1	Used for transmission, display and print. M: Male F: Female U: Unknown	used	approved (NOTE 2)	Send as received
10)	Race	16	Used for transmission, display and print.	used	approved	Send as received
11)	Patient Address	0	-	unused	-	-
12)	Reservation	0	-	unused	-	-
13)	Phone Number	0	-	unused	-	-
14)	Attending Physician ID	32	Used for transmission, display and print.	used	approved	Send as received
15)	Special Field 1	13	Used for transmission, display and print. Social Security #	used	approved	Send as received
16)	Special Field 2	0	-	unused	-	-
17)	Patient Height	0	-	unused	-	-



Field #	Designation	Max. digits	Process upon reception from Host	This system used/unused	Omission	Process on transmission from Analyzer
18)	Patient Weight	0	-	unused	-	-
19)	Patient Known or suspected Diagnosis	0	-	unused	-	-
20)	Patient Active Medications	0	-	unused	-	-
21)	Patient Diet	0	-	unused	-	-
22)	Practice Field #1	0	-	unused	-	-
23)	Practice Field #2	0	-	unused	-	-
24)	Admission and Discharge Dates	0	-	unused	-	-
25)	Admission Status	0	-	unused	-	-
26)	Location	0	-	unused	-	-
27)	Nature of Alternative Diagnostic Code and Classifiers	0	-	unused	-	-
28)	Alternative Diagnostic Code and Classifiers	0	-	unused	-	-
29)	Patient Religion	0	-	unused	-	-
30)	Marital Status	0	-	unused	-	-
31)	Isolation Status	0	-	unused	-	-
32)	Language	0	-	unused	-	-
33)	Hospital Service	0	-	unused	-	-
34)	Hospital Institution	0	-	unused	-	-
35)	Dosage Category	0	-	unused	-	-



- NOTE 1: When “Date of Birth” is omitted, “G2” will be used for normal range.
- NOTE 2: When “Sex” is omitted, “Unknown” will be used for “Sex”. When “Unknown” is selected for “Sex”, “Male” will be used for normal range.

### 3.6. O: Test Order Record

Order for test items are transmitted from Host to Analyzer.

The measurement results of test items requested are transmitted from Analyzer to Host.

Field #	Designation	Max. digits	Process upon reception from Host	This system used/unused	Omission	Process on transmission from Analyzer
1)	Record type "O"	1	abandoned	used	disapproved	Record type "O"
2)	Sequence number	6	abandoned	used	disapproved	-
3)	Sample ID	12	Sample ID 001 to 999999999999 (Except for 910000000001 to 999999999999, 89990001 to 89999999, 91000001 to 99999999)	used	disapproved	Send as received
4)	Equipment specimen ID	0	-	unused	-	-
5)	Universal Test ID	100	Used for measurement. See NOTE 1	used	disapproved	Send as received
6)	Priority	0	-	unused	-	-
7)	Date and time of order	0	-	unused	-	-
8)	Date and time of sample extraction	0	-	unused	-	-
9)	Date and time of completion of sample extraction	0	-	unused	-	-
10)	Extracted volume	0	-	unused	-	-
11)	Name who extracted sample	0	-	unused	-	-
12)	Treatment code	0	-	unused	-	-
13)	Danger code	0	-	unused	-	-
14)	Relevant clinical information	0	-	unused	-	-
15)	Date and time of receipt of sample	0	-	unused	-	-
16)	Specimen Descriptor	0	See NOTE 2	used	approved	Send as received
17)	Ordering Physician	0	-	unused	-	-
18)	Physician's Telephone Number	0	-	unused	-	-



Field #	Designation	Max. digits	Process upon reception from Host	This system used/unused	Omission	Process on transmission from Analyzer
19)	Users Field No.1	0	-	unused	-	-
20)	Users Field No.2	0	-	unused	-	-
21)	Date/Time Results Reported or Last Modified	0	-	unused	-	-
22)	Instrument Charge to Computer System	0	-	unused	-	-
23)	Instrument Section ID	0	-	unused	-	-
24)	Report Types	0	-	unused	-	-
25)	Reserved Field	0	-	unused	-	-
26)	Location or Ward of Specimen Collection	0	-	unused	-	-
27)	Nosocomial Infection Flag	0	-	unused	-	-
28)	Specimen Service	0	-	unused	-	-
29)	Specimen Institution	0	-	unused	-	-





- NOTE 1:  
Universal Test ID for test order record when ISE of ASTM is separated.

Universal Test ID	Description
00	No order
01 - 60	Clinical Chemistry <a href="#">See 7. Annex: Method Numbers table, page 39.</a>
61	ISE (Na)
62	ISE (K)
63	ISE (Cl)
64	Diluted ISE (Na)
65	Diluted ISE (K)
66	Diluted ISE (Cl)
81	Serum Index Test (H, L, I)

Universal Test ID for test order record when ISE of ASTM is not separated.

Universal Test ID	Description
61	ISE (Na, K, Cl)
62	Diluted ISE (Na, K, Cl)

Analyzer transmit Universal Test ID with zero suppress when Universal Test ID is from “1” to “9”.

Use delimiter “^” for delimiting test ID and use “\” for multiple entry of test ID.

(Example 1) In case of order test ID No.1

O|1|001||^^^01

(Example 2) In case of order test ID No.15, 21 and 30

O|1|001||^^^15\^^^21\^^^30

Describe test ID on the each part which is delimited by “^” when ASTM is not complied.

(Example 1) In case of order test ID No.1

O|1|001||01

(Example 2) In case of order test ID No.15, 21 and 30

O|1|001||15^21^30



- NOTE 2: Specimen Type

Specimen Type	Description
01	COMMON
02	SERUM
03	URINE
04	PLASMA

When “Specimen Type” is omitted, “Common” will be used.

### 3.7. R: Result Record

Test results of test items are notified.

Field #	Designation	Max. digits	Process upon reception from Host	This system used/unused	Omission	Process on transmission from Analyzer
1)	Record type	1	Abandoned	used	disapproved	Record type "R"
2)	Sequence number	6	Abandoned	used	disapproved	Refer to 3.3. <a href="#">Sequence Number</a> , page 9.
3)	Universal Test ID	5	Abandoned	used	disapproved	Method code 0 - 3999 See NOTE 1
4)	Test results (Concentration value)	17	Abandoned	used	disapproved	zzzzzzzzzz9.99999 Decimal place which is entered in Chemistry parameter.
5)	Unit	8	Abandoned	used	disapproved	Unit for results
6)	Range of reference value	0	-	unused	-	-
7)	Flag	42	Abandoned	used	disapproved	Followings will be sent. Technical range code, Normal range code, Error flag code, Rerun result flag code, QC flag code 1 - 10. Refer to 3.7.1. <a href="#">Test result error flag code</a> , page 18.
8)	Conditions for the range of reference value	0	-	unused	-	-
9)	Status	0	-	unused	-	-
10)	Date when reference value is changed	0	-	unused	-	-
11)	Operator identification	0	-	unused	-	-
12)	Date and time of commencement of test	0	-	unused	-	-
13)	Date and time of completion of test	14	Abandoned	used	disapproved	YYYYMMDDHHMMSS
14)	Instrument Identification	0	-	unused	-	-





• NOTE 1:  
Universal Test ID for test result record.

Universal Test ID	Description
00	No order
01 - 60	Clinical Chemistry <a href="#">See 7. Annex: Method Numbers table, page 39.</a>
61	ISE (Na)
62	ISE (K)
63	ISE (Cl)
64	Diluted ISE (Na)
65	Diluted ISE (K)
66	Diluted ISE (Cl)
81	Serum Index Test (H)
82	Serum Index Test (L)
83	Serum Index Test (I)
71 - 80	Calculated test See NOTE 2

In case "Full compliance with ASTM rules".

Use delimiter "^" for delimiting test ID.

(Example 1) In case of transmission of test result for test ID No. 1001 to the Host.

R|1|1001||346|mmol/l||00^01^00|||||20040119143714

In case "Non compliance with ASTM rules".

(Example 2) In case of transmission of test result for test ID No. 1001 to the Host.

R|1|1001||346|mmol/l||00^01^00|||||20040119143714

• NOTE 2: The first calculated test (method-to-method calculation) configured on the Analyzer corresponds to the Test ID 71, the second one to the Test ID 72, etc...

### 3.7.1. Test result error flag code

#### 3.7.1.1. Full compliance with ASTM rules

Transmission code	Description	Priority	Display
A	Error occurred	1	Error flag
>	Technical range over "High"	2	>
<	Technical range over "Low"	2	<
H	Normal range over "High"	3	H
L	Normal range over "Low"	3	L
N	Normal	4	no display
LL	Unused	-	-
HH	Unused	-	-
U	Unused	-	-
D	Unused	-	-
B	Unused	-	-
W	Unused	-	-

#### 3.7.1.2. Non compliance with ASTM rules

The "flag" consists of the following 5 codes. The format of flag is

99^99^99^99^99^99^99^99^99^99^99^99 in the order corresponding to Technical range code, Normal range code, Error flag code, Rerun result code and QC flag code from 1 to 10.

Technical range code

Code	Display	Description
00	(None)	Within technical range.
01	>	Technical range over "High"
02	<	Technical range over "Low"



### Normal range code

Code	Display	Description
00	(None)	Within normal range.
01	H	Normal range over "High"
02	L	Normal range over "Low"

### Error flag code

Code	Display	Description
00	-	Normal
01	SS	Sample short
03	SI1	Sample liquid level not detected at aspiration
07	R1S	R1 short
09	R2S	R2 short
11	R1WS	R1 Wash solution short
13	R2WS	R2 Wash solution short
15	DS	Diluent short
17	WS	Wash solution short
19	R1B	R1 reagent bottle not registered.
20	R1S	R1 reagent no inventory
21	R2B	R2 reagent bottle not registered.
22	R2S	R2 reagent no inventory
23	R1WB	R1 wash solution bottle not registered.
24	R1WS	R1 wash solution no inventory
25	R2WB	R2 wash solution bottle not registered.
26	R2WS	R2 wash solution no inventory
27	DB	Diluent bottle not registered.
28	DS	Diluent no inventory

### Error flag code

Code	Display	Description
29	WB	Wash solution bottle not registered.
30	WS	Wash solution no inventory
31	EST	Sampling stop due to error
32	LOT	Reagent lot number mismatch
33	SPW	SPT wash failure
34	R1W	RPT wash between methods failed (R1)
35	R2W	RPT wash between methods failed (R2)
40	TE1	IRU temperature less than 35 degrees centigrade.
41	TE2	IRU temperature more than 39 degrees centigrade.
42	TE3	RCU temperature more than 15 degrees centigrade.
43	TE4	RCU temperature less than 2 degrees centigrade.
50	EXP	Measured with expired reagent
51	STB	Measured with expired onboard stability reagent
52	CTO	Terms of validity of calibration is expired
53	CXP	Control expired
54	SXP	Calibrator expired
55	Q	Q error
60	IE1	No response from ISE module.
61	IE2	No measurement results from ISE module.
70	CA?	Concentration calculation failure
71	OVR	Calibrator out of valid range error
72	LIN	Linearity Limit error
73	PRO	Prozone Limit error
74	AB1	Absorbance Limit1 error
75	AB2	Absorbance Limit2 error
76	DUP	Duplicate Limit error



### Error flag code

Code	Display	Description
77	SEN	Sensitivity Limit error
78	CAL	Calibration failed
79	SDE	Standard Deviation range check error
80	KOV	K variation check error
81	S1E	S1 calibrator check error
82	STM	Sample type mismatch
83	CLT	Reagent lot mismatch
84	DWPB	DET.W(P.T) bottle not in place
85	DWPS	DET.W(P.T) bottle has no inventory
86	DWMB	DET.W(MIX) bottle not in place
87	EUT	No usage record of DET.W(MIX) bottle
88	CS	Not enough cuvettes
89	DF	Full cuvette waste box

### Rerun result code

Code	Description
00	First result
01	Rerun result

The QC flag code consists of 10 fields.

### QC flag code

Field	Description	QC flag code
1	Current result exceeds 2SD	00: Normal, 01: Warning, 02: Error
2	Current result exceeds 3SD	00: Normal, 01: Warning, 02: Error
3	Current result exceeds 4SD	00: Normal, 01: Warning, 02: Error
4	Last two results exceed 2SD range	00: Normal, 01: Warning, 02: Error
5	2 results out of 3 last results exceed 2SD	00: Normal, 01: Warning, 02: Error
6	Range for a defined period exceeds 4SD	00: Normal, 01: Warning, 02: Error
7	Any 3 results for a defined period exceed 1SD	00: Normal, 01: Warning, 02: Error
8	Any 4 results for a defined period exceed 1SD	00: Normal, 01: Warning, 02: Error
9	Last 10 results higher or lower than mean	00: Normal, 01: Warning (higher), 02: Error (higher)
10	Last 7 results trend	00: Normal, 01: Warning (increasing), 02: Error (increasing)



• NOTE 1: Only methods that are set as "Warning" or "Error" on QC -> QC setting of UI software will be valid. All items set as "Inactive" at QC, QC settings screen will be set to "00".

• NOTE 2: Results for non QC measurements such as normal, emergency and standards will have "00" for all 10 fields.

### 3.8. C: Comment Record

Comment record can be sent following the records below;

Patient Information record, Test Order record, Result record, Scientific record and Manufacturer Information record. The level of the comment record will be one level higher than the previous level.

Field #	Designation	Max. digits	Process upon reception from Host	This system used/unused	Omission	Process on transmission from Analyzer
1)	Record type	1	Abandoned	used	disapproved	Record type "C"
2)	Sequence number	6	Abandoned	used	disapproved	-
3)	Source of comment	1	Fixed to "L"	used	disapproved	Fixed to "1"
4)	Text of comment	50 40	Refer to the table below.	used	disapproved	Status of Analyzer (separately defined) Up to 15 characters on UI screen.
5)	Type of comment	1	Refer to the table below.	used	disapproved	Set to "G"

Preceding message	Comment type	Usage of comment text
Patient	G	Abandon
Order	G	Reflect sample information
Result	-	Unused
Scientific	G	Abandon
Manufacturer	G	Abandon



### 3.9. Q: Request Information Record

On real-time mode, this string will be used on every order inquiry. On batch mode, this string will be used when acquiring test.

Field #	Designation	Max. digits	Process upon reception from Host	This system used/unused	Omission	Process on transmission from Analyzer
1)	Record type	1	Abandoned	used	disapproved	Record type "Q"
2)	Sequence number	1	Abandoned	used	disapproved	Fixed to "1"
3)	Starting Range ID #	12	Abandoned	used	disapproved	Fixed to "ALL" for batch
4)	Ending Range ID #	0	-	unused	-	-
5)	Universal Test ID	0	-	unused	-	-
6)	Nature of Request Time Limits	0	-	unused	-	-
7)	Beginning Request Results Date and Time	0	-	unused	-	-
8)	Ending Request Results Date and Time	0	-	unused	-	-
9)	Request Physician Name	0	-	unused	-	-
10)	Request Physician Telephone Number	0	-	unused	-	-
11)	User Field No.1	0	-	unused	-	-
12)	User Field No.2	0	-	unused	-	-
13)	Request Information Status Code	1	Abandoned	used	disapproved	Fixed to "N"



### 3.10. L: Message Terminator Record

This string will be used when termination of transmission.

Field #	Designation	Max. digits	Process upon reception from Host	This system used/unused	Omission	Process on transmission from Analyzer
1)	Record type	1	Abandoned	used	disapproved	Record type "L"
2)	Sequence number	1	Abandoned	used	disapproved	Fixed to "1"
3)	Termination Code	0	-	unused	-	-

### 3.11. S: Scientific Record

Field #	Designation	Max. digits	Process upon reception from Host	This system used/unused	Omission	Process on transmission from Analyzer
1)	Type	1	Abandoned	used	disapproved	Record type "S"
2)	Sequence number	1	Abandoned	used	disapproved	Fixed to "1"
3)	Analytical Method	0	-	unused	-	-
4)	Instrumentation	0	-	unused	-	-
5)	Reagents	0	-	unused	-	-
6)	Units of Measure	0	-	unused	-	-
7)	Quality Control	0	-	unused	-	-
8)	Specimen Descriptor	0	-	unused	-	-
9)	Reserved Field	0	-	unused	-	-
10)	Container	0	-	unused	-	-
11)	Specimen ID	0	-	unused	-	-
12)	Analyte	0	-	unused	-	-
13)	Result	0	-	unused	-	-
14)	Result Units	0	-	unused	-	-
15)	Collection Date and Time	0	-	unused	-	-
16)	Result Date and Time	0	-	unused	-	-



Field #	Designation	Max. digits	Process upon reception from Host	This system used/unused	Omission	Process on transmission from Analyzer
17)	Analytical Preprocessing Steps	0	-	unused	-	-
18)	Patient Diagnosis	0	-	unused	-	-
19)	Patient Birth date	0	-	unused	-	-
20)	Patient Sex	0	-	unused	-	-
21)	Patient Race	0	-	unused	-	-

### 3.12. M: Manufacturer Information Record

The manufacturer information record can be sent following the records below; Patient Information record, Test Order record, Result record, Scientific record and Manufacturer Information record. The level of the comment record will be one level higher than the previous level.

Field #	Designation	Max. digits	Process upon reception from Host	This system used/unused	Omission	Process on transmission from Analyzer
1)	Record type	1	Abandoned	used	disapproved	Record type "M"
2)	Sequence number	1	Abandoned	used	disapproved	Fixed to "1"



## 4. Communication sequence

### 4.1. Communication Modes

The following table describes the test ordering functions for each communication mode.

Mode	Status	Local	Batch	Real-time
Real-time	During RUN	Emergency samples can be entered manually. Test orders can be edited.	-	Inquire orders for normal samples. Emergency samples can only be handled locally.
	Stand-by	Normal and Emergency samples can be entered manually. Test orders can be edited.	-	-
Batch (NOTE 1)	During RUN	Emergency samples can be entered manually. Test orders can be edited.	-	-
	Stand-by	Normal and Emergency samples can be entered manually. Test orders can be edited.	Acquire test orders for normal sample from Host by clicking on "Acquire" button on screen.	-
Off line	During RUN	Emergency samples can be entered manually. Test orders can be edited.	-	-
	Stand-by	Normal and Emergency samples can be entered manually. Test orders can be edited.	-	-

The following table describes the result output functions for each communication mode.

Mode	Status	Local	Batch	Real-time
Real-time	During RUN	Search, Edit and printout available	-	Send result to Host as soon as available
	Stand-by	Search, Edit and printout available	-	No action
Batch (NOTE 1)	During RUN	Search, Edit and printout available	Disapproved	Send result to Host as soon as available
	Stand-by	Search, Edit and printout available	Send test results to Host by choosing "Host" as destination.	No action
Off line	During RUN	Search, Edit and printout available	-	-
	Stand-by	Search, Edit and printout available	-	-



- NOTE 1: The batch mode is a batch mode with a capability of real-time result transmission to the Host.
- NOTE 2: An emergency sample should be handled locally not via Host.
- NOTE 3: The result for normal, emergency, on-line and control samples can be sent to Host.
- NOTE 4: All result obtained at off line, batch and real-time modes will be stored in one database.

## 5. Communication Sequence

### 5.1. Confirmation of Connection Sequence

#### 5.1.1. Connection confirmation at beginning of each round (On-Line Batch mode/Real-time mode)

Analyzer will check communication status with Host at beginning of each round.

This to ensure the communication condition prior to an order inquiry of samples at measurement.

For the Host side, communication status confirmation is required at beginning of each round.

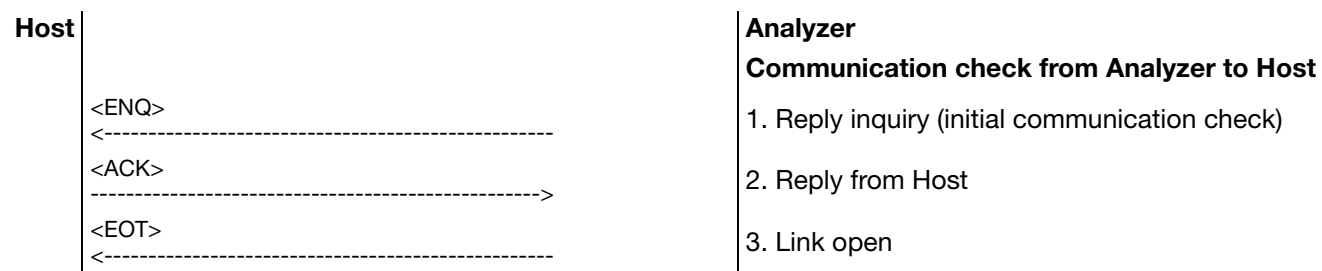

When reply from the Host is <NAK> or no response, Analyzer will re-try up to 6 times.

If <NAK> or no reply continues for 6 times, Analyzer will generate error message and will not proceed with the round.

## 5.2. Batch Sequence

### 5.2.1. Batch transmission of result to Host

Following is the example of communication on on-line batch mode with result transmission operation.

Host	Analyzer
H \^&  Analyzer       20010111055300<CR> <----->	1. Message Header Record
P 1 PID2734   Last^Middle^First  19630501 M Race1    AttenPhID 1234567890123<CR> <----->	2. Patient Information Record
O 1 001  ^1<CR> <----->	3. Test Order Record
C 1  TestOrder1 G<CR> <----->	4. Comment Record
R 1 ^1 15.265 mg/ml     20010110121530<CR> <----->	5. Result Record
O 2 001  ^3<CR> <----->	6. Test Order Record
R 1 ^3 18.052 mg/ml     20010110121830<CR> <----->	7. Result Record
P 2 PID2738   Last^Middle^First2  19870501 M Race1    AttenPhID 1234567890153<CR> <----->	8. Patient Information Record
O 1 890051  ^5<CR> <----->	9. Test Order Record
C 1  TestOrder2 G<CR> <----->	10. Comment Record
R 1 ^5 5.265 mg/ml     20010110151530<CR> <----->	11. Result Record



Host	Analyzer
P 9 PID2755   Last^Middle^First9  19870501 M Race1    AttenPhID 1234567890553<CR> <-----	12. Patient Information Record
O 1 8900171  ^37<CR> <-----	13. Test Order Record
C 1  TestOrder3 G<CR> <-----	14. Comment Record
R 1 ^37 0.265 mg/ml   20010110171530<CR> <-----	15. Result Record
L 1<CR> <-----	16. Message Terminator Record



- NOTE 1: Comment information can be omitted.
- NOTE 2: There can be multiple messages of test order and test result for one patient information.
- NOTE 3: Result record with error flag is not transmitted when it is set not to transmit result record when error occurred.

### 5.2.2. Inquiry to Host for order and response

The following is an example of communication when test order acquisition operation was done at test ordering screen at on-line batch mode. The test order acquired will be added or over written to the existing order after it is confirmed and edited.

Host	Analyzer
H \^&  Analyzer   20010111055300<CR> <-----	<b>Inquiry from Analyzer to Host</b>
Q 1 ALL   N<CR> <-----	1. Message Header Record
L 1<CR> <-----	2. Request Information Record
	3. Message Terminator Record



	Host	Analyzer
	<b>Response from Host</b>	
4. Message Header Record	H ^&    Host     20010111055303<CR> ----->	
5. Patient Information Record	P 1 PID2734   Last^Middle^First  19630501 M Race1    AttenPhID 1234567890123<CR> ----->	
6. Test Order Record	O 1 001  ^1^1^1^1^03<CR> ----->	
7. Comment Record	C 1  TestOrder1 G<CR> ----->	
8. Patient Information Record	P 2 PID2738   Last^Middle^First2  19870501 M Race1    AttenPhID 1234567890153<CR> ----->	
9. Test Order Record	O 1 890051  ^5<CR> ----->	
10. Comment Record	C 1  TestOrder2 G<CR> ----->	
11. Patient Information Record	P 9 PID2755   Last^Middle^First9  19870501 M Race1    AttenPhID 1234567890553<CR> ----->	
12. Test Order Record	O 1 8900171  ^37<CR> ----->	
13. Comment Record	C 1  TestOrder3 G<CR> ----->	
14. Message Terminator Record	L 1<CR> ----->	



- NOTE 1: Comment information can be omitted.
- NOTE 2: There can be multiple messages of test order and test result for one patient information.



### 5.3. Real-time Sequence

#### 5.3.1. Real-time inquiry to Host for one sample and its response

The inquiry is made at on-line real-time mode during run to obtain test order from Host.

	Host	Analyzer
	H \^&   Analyzer       20010111055300<CR> <----->	<b>Inquiry from Analyzer to Host</b>
	Q 1 910000000001       N<CR> <----->	1. Message Header Record
	L 1<CR> <----->	2. Request Information Record
		3. Message Terminator Record
	<b>Response from Host</b>	
4. Message Header Record	H \^&   Host       20010111055303<CR> ----->	
5. Patient Information Record	P 1 PID2734   Last^Middle^First  19630501 M Race1    AttenPhID 1234567890123<CR> ----->	
6. Test Order Record	O 1 910000000001  ^01\^^^3<CR> ----->	
7. Comment Record	C 1  TestOrder1 G<CR> ----->	
8. Message Terminator Record	L 1<CR> ----->	



- NOTE 1: When there is no order for inquired sample, return order information with empty universal test ID field ("00").
- NOTE 2: When rerun is not required at Host rerun mode, return order information with empty universal test ID field ("00"). However, auto rerun is performed for the method which is set as auto rerun.
- NOTE 3: Comment information can be omitted.

### 5.3.2. Real-time transmission of result to Host for one sample

The result is transmitted to Host when results for a sample is obtained during run. This transmission is performed at on-line real-time mode and on-line batch mode.

Host	Analyzer
H \^&  Analyzer       20010111055300<CR> <----->	1. Message Header Record
P 1 PID2734   Last^Middle^First 19630501 M Race1    AttenPhID 1234567890123<CR> <----->	2. Patient Information Record
O 1 91000000001  ^^^1<CR> <----->	3. Test Order Record
C 1  TestOrder1 G<CR> <----->	4. Comment Record
R 1 ^^^1 15.265 mg/ml       20010110121530<CR> <----->	5. Result Record
L 1<CR> <----->	6. Message Terminator Record



- NOTE 1: Result is sent for one method per sample at a time.
- NOTE 2: Universal test ID for test order record is transmitted as ID with the result.
- NOTE 3: In case of result with an error, lines “H” to “L” are not transmitted if the setting is not transmitted result record when error occurred.

## 6. Error Handling

### 6.1. Transmission error

When transmission of a message has caused an error, re-transmission of the message will be carried out from high level message.  
The buffered data will be save at reception of higher level message.

Host	Analyzer
H \^&  Analyzer       20010111055300<CR> <----->	1. Message Header Record
P 1 PID2734   Last^Middle^First  19630501 M Race1    AttenPhID 1234567890123<CR> <----->	2. Patient Information Record
O 1 001  ^1<CR> <----->	3. Test Order Record
C 1  TestOrder1 G<CR> <----->	4. Comment Record
R ^1 15.265 mg/ml     20010110121530<CR> <----->	5. Result Record
O 2 001  ^3<CR> <----->	6. Test Order Record
R ^3 18.052 mg/ml     20010110121830<CR> <----->	7. Result Record
P 2 PID2738   Last^Middle^First2  19870501 M Race1    AttenPhID 1234567890153<CR> <----->	8. Patient Information Record
O 1 890051  ^5<CR> <----->	9. Test Order Record
C 1  TestOrder2 G<CR> <----->	10. Comment Record
R ^5 5.265 mg/ml     20010110151530<CR> <----->	11. Result Record



**Host**

```
P|9|PID2755|||Last^Middle^First9||19870501|M|Race1|||
AttenPhID|1234567890553<CR>
<-----
O|1|8900171||^^^37<CR>
<-----
C|1||TestOrder3|G<CR>
<-----
R|1|^37|0.265|mg/ml|||20010110171530<CR>
<-----
L|1<CR>
<-----
```

**Analyzer**

- 12. Patient Information Record
- 13. Test Order Record
- 14. Comment Record
- 15. Result Record
- 16. Message Terminator Record

Error occurring message	Re-transmission message
1)	1)
2)	1) 2)
3)	1) 2) 3)
4)	1) 2) 3) 4)
5)	1) 2) 3) 4) 5)
6)	1) 2) 3) 4) 5) 6)
7)	1) 2) 3) 4) 5) 6) 7)
8)	1) 2) 3) 4) 5) 6) 7) 8)
9)	1) 8) 9)
10)	1) 8) 9) 10)
11)	1) 8) 9) 10) 11)
12)	1) 8) 9) 10) 11) 12)
13)	1) 12) 13)
14)	1) 12) 13) 14)
15)	1) 12) 13) 14) 15)
16)	1) 12) 13) 14) 15) 16)



## 6.2. Reception Error

### 6.2.1. Error during batch order inquiry and its response

When message “4” is not received for T1 time out time after transmitting “3”, it will be handled as described on the table below. For the messages 5) to 14) will be handled as an error in case message is not received for T2 time out time.

	Host	Analyzer
	H \^&  Analyzer     20010111055300<CR> <----->	<b>Inquiry from Analyzer to Host</b>
	Q 1 ALL     N<CR> <----->	1. Message Header Record
	L 1<CR> <----->	2. Request Information Record
		3. Message Terminator Record
	<b>Response from Host</b>	
4. Message Header Record	H \^&  Host     20010111055303<CR> ----->	
5. Patient Information Record	P 1 PID2734   Last^Middle^First  19630501 M Race1    AttenPhID 1234567890123<CR> ----->	
6. Test Order Record	O 1 001  ^01^^^3<CR> ----->	
7. Comment Record	C 1  TestOrder1 G<CR> ----->	
8. Patient Information Record	P 2 PID2738   Last^Middle^First2  19870501 M Race1    AttenPhID 1234567890153<CR> ----->	
9. Test Order Record	O 1 890051  ^5<CR> ----->	
10. Comment Record	C 1  TestOrder2 G<CR> ----->	



	Host	Analyzer
11. Patient Information Record	P 9 PID2755   Last^Middle^First9  19870501 M Race1    AttenPhID 1234567890553<CR>	
12. Test Order Record	O 1 8900171  ^37<CR>	
13. Comment Record	C 1  TestOrder3 G<CR>	
14. Message Terminator Record	L 1<CR>	

Error occurring message	Error handling
4) to 14)	Re-transmit 1), 2) and 3)



- NOTE 1: Maximum re-transmission is three. When retry time over occurs, popup menu appears on the screen to check connection.
- NOTE 2: T1=10 seconds, T2= 5 seconds

### 6.2.2. Error during test order inquiry for a sample at real-time mode

	Host	Analyzer
	H \^&  Analyzer     20010111055300<CR>	<b>Inquiry from Analyzer to Host</b>
	<----->	1. Message Header Record
	Q 1 91000000001     N<CR>	2. Request Information Record
	<----->	3. Message Terminator Record
	L 1<CR>	
	<----->	
<b>Response from Host</b>		

	Host	Analyzer
4. Message Header Record	H \^&   Host       20010111055303<CR> ----->	
5. Patient Information Record	P 1 PID2734   Last^Middle^First  19630501 M Race1    AttenPhID 1234567890123<CR> ----->	
6. Test Order Record	O 1 910000000001  ^1\^3<CR> ----->	
7. Comment Record	C 1  TestOrder1 G<CR> ----->	
8. Message Terminator Record	L 1<CR> ----->	

Error occurring message	Error handling
4) to 8)	Re-transmit 1), 2) and 3)

### 6.3. Abnormal data

Followings are the error handling when abnormal data is found.

#### 6.3.1. Sequence Number

A duplicate sequence number will discarded and missing sequence number will inquired.

#### 6.3.2. Abnormal data

Type of Message	Type of Field	Description
Message Header	Delimiter	When invalid character is assigned, the system used default delimiters.
Patient Information	Patient ID	When patient ID with new information such as name, date of birth, sex, Attending physician ID and SS# is received, all data process after the reception will be based on new information.
Test Order	Sample ID	Test orders with invalid sample ID will be ignored. No warning or error message is displayed.
	Method	Tests ordered with methods not registered, short reagent, or no reagent will not be run. Other available tests ordered together with invalid methods will be run. Message will be shown on screen to notify operator.

### 6.4. Retry over

Sequence	Process
Batch transmission of results to Host	Display error on screen. Operation other than Host communication will be continued.
Inquiry for test orders to Host	Display error on screen. Operation other than Host communication will be continued.
Real-time inquiry for test order for a sample	Generate an error. Transmit "No order" to analyzer. Operation other than Host communication will be continued.
Real-time result transmission to Host	Generate an error. Results that were not transmitted to the Host will be saved in database. Saved results can be transmitted manually from result search screen.



## 7. Annex: Method Numbers table



The Method Numbers table is given as an example for the first version of HORIBA Medical applications. Please note that the information contained in this table can evolve according to the version number of HORIBA Medical applications and the customer configuration of open channels.

Method Number	Method Name	Method Number	Method Name	Method Number	Method Name
01	T1	21	GLUP	41	CRP
02	ALP	22	GLUHK	42	FERR
03	ALT				
04	AST	24	IRON	44	HBA1
05	AMY	25		45	THB
06	CK	26	MG		
07	CKMB	27	PHOS		
08	GGT	28	TP		
09	LDH	29	TPU		
		30	TRIG	50	SDye
11	ALB	31	UA	51	LDHi
12	TBIL	32	UREA		
13	DBIL			53	CaARZ
14	CA	34	MALB	54	TP100
15	CHOL			55	RF
16	HDL			56	OPEN1
17	LDL	37	ASO	57	OPEN2
18	CO2			58	OPEN3
19	CREA			59	OPEN4
				60	OPEN5



The same Method Number can be used for several specimen types (common, serum, urine, plasma). The specimen type should be described in its own field.



