



Coagulation Analyzer: Yumizen G800/G800h/G850h

Output Format for Host Connection

Ref: RAA073CEN

Output Format for Host Connection



CE

IVD



HORIBA ABX SAS
Parc Euromédecine
Rue du Caducée
BP 7290
34184 Montpellier Cedex 4
FRANCE

Contents

1. Foreword.....	1
1.1. Document Update.....	1
2. Online test.....	2
2.1. Description.....	2
2.2. Checking the serial ports.....	2
2.3. Checking the Online connection.....	3
3. Online Communication Specification.....	6
3.1. Overview.....	6
3.2. Physical layer.....	6
3.3. Standards.....	7
3.4. Control character definitions.....	7
3.5. Exchange protocol.....	7
3.6. Record definitions.....	9
3.7. Test Order Codes.....	15
3.8. Example.....	16



1. Foreword

1.1. Document Update

1.1.1. Revisions

Internal Reference	Software Version used for Documentation	Document Date Issued
RAA073AEN	2.34	12/2018
RAA073BEN	2.38	12/2023
RAA073CEN	2.39	07/2025

This document applies to the latest software version listed and higher versions.

When a subsequent software version changes the information in this document, a new electronic edition is released and supplied by HORIBA.

1.1.2. What's New?

Update	Chapter
LAN connection addition	Physical layer
Information update: field 10.1.7 <ul style="list-style-type: none">field supported from instrument to hostaddition of flag E	(R)esult Record

2. Online test

2.1. Description

The OnLine test program is used to check the online communication in between the Yumizen G800/G800h/G850h instrument and the Host. The test should be performed by a person with administrator level only.

2.2. Checking the serial ports

First switch the Host computer on then switch the Yumizen G800/G800h/G850h instrument on.

1. Before start the OnLine test, please check the USB (Universal Serial Bus) ports in Windows and in Yumizen G800/G800h/G850h instrument program:
 - a. Check the three USB ports in Windows by Device Manager.
 - b. Check the serial ports in System Settings menu. Each serial ports must be different.

The serial ports should have the same numbers in Yumizen G800/G800h/G850h instrument software as in the Windows Device Manager.

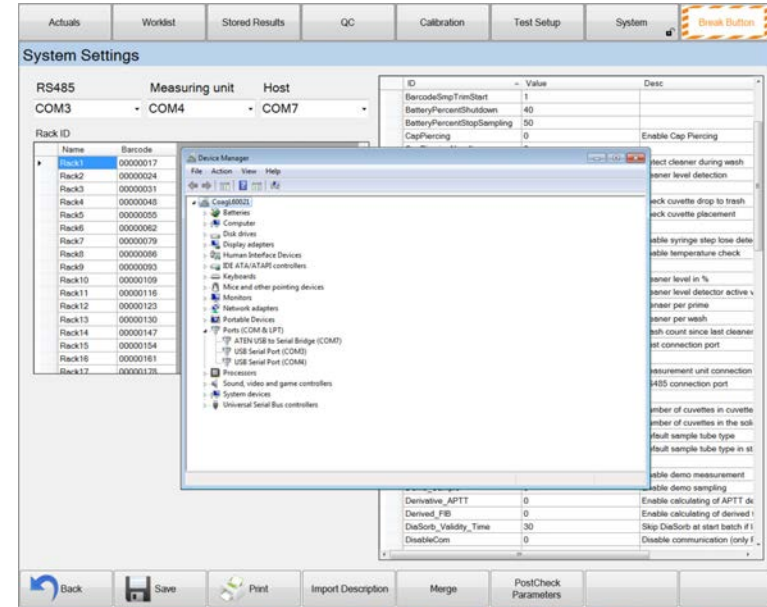

In the example:

- the USB Serial Port (Com4) is used for RS485 communication,
- the USB Serial Port (Com3) is used for Measuring Unit,
- the USB Serial Port (Com7) is used for the Host communication.

2. Ensure that the "Online" button is on in the Actual menu (Main screen).
The following example shows that the "Online" button is on but there is something wrong with the online connection.



If everything seems to be good with the Host connection, the "Online button is on as follows:



2.3. Checking the Online connection

2.3.1. Basic menu for online checking

1. Press the **System** button.
2. Type the admin password and then click the **Ok** button.

3. Choose **Settings**.
4. Choose **Endurance Test**.
5. Choose **Online**.

The next picture shows that the OnLine test program is in Yumizen G800/G800h/G850h instrument **System > Endurance Test > Online** menu. If the online connection is working, the right side shows the communication with host.

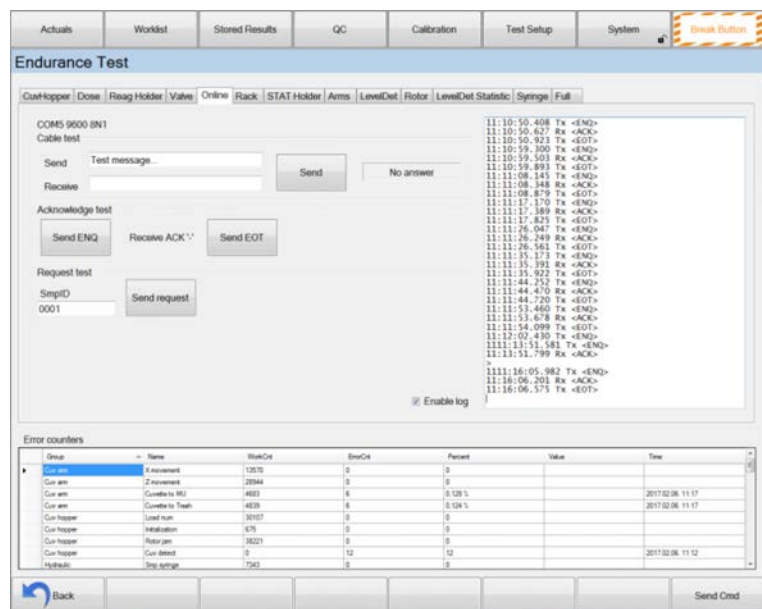

2.3.2. The receive and send control commands

1. Press the **"Send ENQ"** button.
On the right side of the screen and you will see the ... characters.
2. Press the **"Send EOT"** button.
On the right side of the screen and you will see the ... characters.

2.3.3. Request test

1. Type a sample ID to the SmpID input window.
2. Press the **"Send request"** button
On the right side of the screen you will see the characters, which the Host has sent.

If the online connection is working, the right side shows the communication with host.

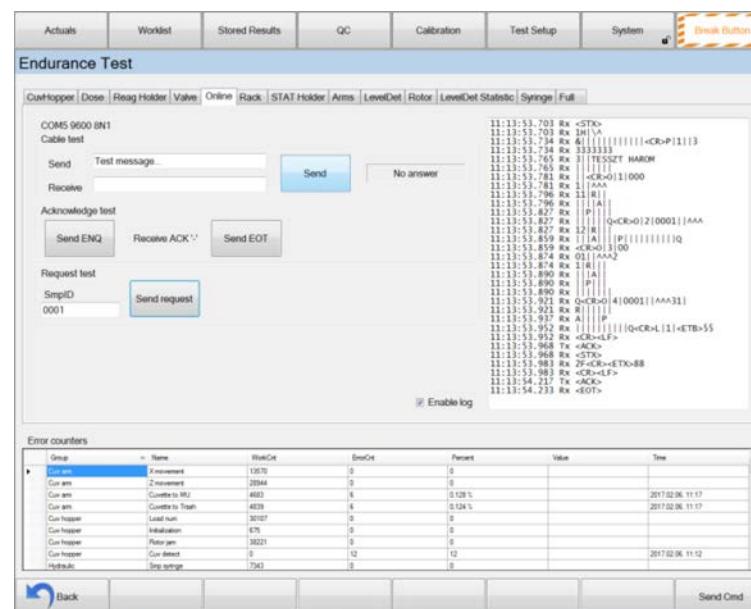

2.3.4. Communication cable and USB to serial converter test

1. Ensure that the USB to serial converter is plugged to a right USB port at the back of Yumizen G800/G800h/G850h instrument.
2. Ensure that one end of the USB cable is connected to the USB to serial converter.

Online test

Checking the Online connection

3. Plug the "loopback test plug" to the other end of the serial cable.
4. Type a some characters to the **Send input** window.
5. Press the "**Send**" button.
6. Check the **Receive** windows.

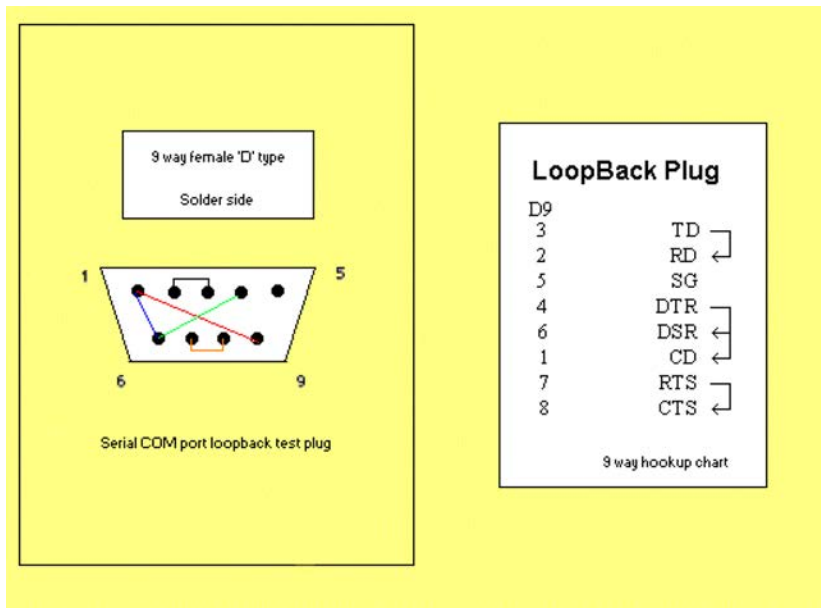

Loopback test plug for the communication cable test

If the serial cable and the USB to serial converter is working well, the **Send** and the **Receive** windows should be the same.

7. If there is no received character or different the received characters:
 - a. Check the serial cable.
 - b. Replace the USB to serial converter.

3. Online Communication Specification

3.1. Overview

The purpose of this document is to specify the complete online communication protocol of Yumizen G800/G800h/G850h instrument, both on server and client side.

3.2. Physical layer

3.2.1. RS232 Connection Mode

Interface: asynchronous, serial, RS232C standard

Connector: DB9 male (USB to Serial converter)

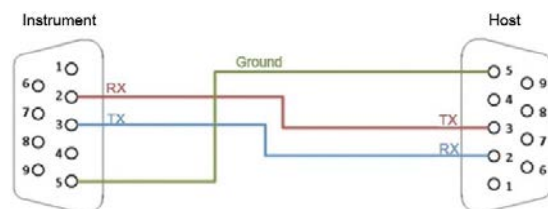

pin 2: RX
pin 3: TX
pin 5: GND

Baud rate: 9600 baud

Data bits: 8

Parity: none

Stop bits: 1

Flow control: software with control characters

You can configure the RS232 connection mode in **System > Settings**.

COM_HOST	COM2	COM1	Host connection port
COM_HOST_Baudrate	9600	9600	Communication rate of the Host con

3.2.2. Local Area Network (LAN) Connection Mode

Connector: RJ45

Cable: UTP CAT5 or higher

Protocol: TCP/IP

Default IP address: 192.168.0.1

Default IP port: 23

You can configure the LAN connection mode in **System > Settings**.

Host_IP	10.36.1.152	192.168.0.1	Host computer's IP address
Host_Port	10001	23	Host computer's port number

3.3. Standards

The ASTM connection protocol on Yumizen G800/G800h/G850h instrument is based on the following standards:

- E1238 Specification for Transferring Clinical Observations Between Independent Computer Systems
- E1381 Specification for Low-Level Protocol to Transfer Messages Between Clinical Instruments and Computer Systems
- E 1394-97 Standard Specification for Transferring Information Between Clinical Instruments and Computer Systems

3.4. Control character definitions

Identifier	Code	Description
<STX>	02h	Start of text transmission
<ETX>	03h	End of text transmission
<ACK>	06h	Acknowledge without error
<NACK>	15h	Acknowledge with error
<ENQ>	05h	Request for line (enquiry)
<EOT>	04h	End of transmission
<ETB>	17h	End of transmission block
<CR>	0dh	Carriage return
<LF>	0ah	Line feed

3.5. Exchange protocol

Example of Host Computer to Yumizen G800/G800h/G850h instrument Exchange:

Yumizen G800/G800h/G850h instrument		Host
<ENQ>	→	
	←	<ACK>
<STX>1[DATA1]<ETB>[CS1] [CS2]<CR><LF>	→	
	←	<ACK>
<STX>2[DATA2]<ETB>[CS1] [CS2]<CR><LF>	→	
	←	<ACK>
<STX>3[DATA3]<ETX>[CS1] [CS2]<CR><LF>	→	
	←	<ACK>
<EOT>	→	
		No response expected

3.5.1. Exchange block structure

	Size in characters	Description
<STX>	1	Start of text transmission
x	1	Block number ('0'..'7') increased by 1, first block is number '1'
[DATAx]	1..240	Sent data (max. 240 character)
<ETX> or <ETB>	1	End of text transmission
[CS1][CS2]	2	Checksum

	Size in characters	Description
<CR>	1	Carriage return
<LF>	1	Line feed

If the sender wants to send more than 240 characters long data, the message must be broken max. 240 characters blocks. At the end of each block <ETB> character indicates the additional message block(s) goes by. The <ETX> of last block indicates that this is the last.

3.5.2. Checksum calculation

The checksum is computed by adding the binary values of the character starting with the block number to the <ETX> (or <ETB>) character, keeping the least significant eight bits of the result. (The <STX> is not included in the summary. $CS = x + [DATAx] + <ETX>$.) The checksum is encoded as two characters in hexadecimal format, and transmitted as ASCII characters in [CS1][CS2].

E.g: The checksum is 138 (hexadecimal 8A), then CS1 = '8', CS2 = 'A'.

3.5.3. Checking continuous connection

To check the continuous online connection, the Yumizen G800/G800h/G850h instrument requests a transmission every 30 seconds if there aren't any online data. The 30 seconds timer starts from the last data exchange. If there aren't any valid data in this time gap, then the exchange protocol is shown on the following table:

Yumizen G800/G800h/G850h instrument		Host
<ENQ>	→	
	←	<ACK>
<EOT>	→	

3.5.4. Data exchange from Host to Yumizen G800/G800h/G850h instrument

The Host transmits data only for requests from Yumizen G800/G800h/G850h instrument (e.g. Q record). The protocol is shown on the following table:

Yumizen G800/G800h/G850h instrument		Host
<ENQ>	→	
	←	<ACK>
<STX>1[DATA1]<ETB>[CS1][CS2]<CR><LF>	→	
	←	<ACK>
<STX>2[DATA2]<ETB>[CS1][CS2]<CR><LF>	→	
	←	<ACK>
<STX>3[DATA3]<ETX>[CS1][CS2]<CR><LF>	→	
	←	<ACK>
<EOT>	→	
	←	<ENQ>
<ACK>	→	
	←	<STX>1[DATA1]<ETB>[CS1][CS2]<CR><LF>
<ACK>	→	
	←	<STX>2[DATA2]<ETB>[CS1][CS2]<CR><LF>
<ACK>	→	
	←	<STX>3[DATA3]<ETX>[CS1][CS2]<CR><LF>
<ACK>	→	
	←	<EOT>

3.5.5. Transmission of <NACK>

If an error has been found in the data exchange, then the recipient sends <NACK>. This state occurs on the following cases:

- The checksum doesn't match
- Formatting error (wrong control character)
- Timeout

If an error occurred during the data exchange, the sender retransmits the last block.

3.5.6. Timeout

There is a 2 minutes timeout while the Yumizen G800/G800h/G850h instrument is waiting for data from the Host computer. If there's no received data within this time, then the instrument assumes that the connection have been lost.

3.6. Record definitions

3.6.1. Message (H)header Record

Purpose: To identify the sender.

Yumizen G800/G800h/G850h implementation example:

H|\^&|H60039_1||G800^H60039|||||HOST||P|1394-97|20130919114039

Description of a Message Header Record on Yumizen G800/G800h/G850h:

Paragraph's number of E 1394-97 standard	Character	Field description	Supported	
			Upload (Instrument > Host)	Download (Host > Instrument)
7.1.1	H	Record Type ID = header record	Yes	Yes
7.1.2		Delimiter definition =defined as field delimiter (7Ch)	Yes	Yes
	\	=defined as repeat filed delimiter (5Ch)		
	^	=defined as component delimiter (5Eh)		
	&	=defined as Escape delimiter (26h)		
7.1.3	H60039_1	Unique message ID (device serial number plus an increasing number)	Yes	No
7.1.4		Access Password	No	No
7.1.5	G800^H60039	Sender name or ID G800 (fixed data)	Yes	Yes
7.1.6		Sender Street Address	No	No
7.1.7		Reserved Field	No	No
7.1.8		Sender Telephone Number	No	No
7.1.9		Characteristics of sender	No	No
7.1.10	HOST	Receiver ID (fixed date)	Yes	Yes
7.1.11		Comment or Special Instructions	No	No

Paragraph's number of E 1394-97 standard	Character	Field description	Supported	
			Upload (Instrument > Host)	Download (Host > Instrument)
7.1.12		Processing ID		
	P	P=Production	Yes	No
		Q=Quality Control	No	No
		T=Training	No	No
		D=Debugging	No	No
7.1.13	 1394-97	Version Number =Version level of ASTM specifications (E 1394-91)	Yes	No
7.1.14		Date and Time of Message	Yes	No
	20130919114039	Format: yyyymmddhhmmss		
		yyyy = year		
		mm= month		
		dd = day		
		hh = hour		
		mm = minutes		
		ss = seconds		
	<CR>	carriage return		

Description of a Patient Information Record on Yumizen G800/G800h/G850h:

Paragraph's number of E 1394-97 standard	Character	Field description	Supported	
			Upload (Instrument > Host)	Download (Host > Instrument)
8.1.1	P	Record Type ID= Patient record (50h)	Yes	Yes
8.1.2	 1	Sequence number	Yes	Yes
8.1.3		Practice Assigned Patient ID	No	No
8.1.4	 654789321	Laboratory Assigned Patient ID	No	Yes
8.1.5		Other Patient ID	No	No
8.1.6	 John Doe	Patient Name	Yes	Yes
8.1.7		Mother's birth name	No	No
8.1.8	 19800101	Date of birth	Yes	Yes
8.1.9	 F	Sex F=Female M=Male	Yes	Yes
8.1.10		Race	No	No
8.1.11		Address	No	No
8.1.12		Reserved	No	No
8.1.13		Telephone number	No	No
8.1.14	 House MD	Prescriber's name	Yes	Yes
8.1.15		Special Q = Quality Control	Yes	No
8.1.16	 INT	Special, Prescriber ward	Yes	Yes
	<CR>	Carriage return		

3.6.2. (P)atient Information Record

Purpose: To give information on the Patient.

Yumizen G800/G800h/G850h implementation example:

P|1||654789321||John Doe||19800101|F||||House MD||INT

3.6.3. Test (O)rder Record

Purpose:

- In downloading (Host -> Yumizen G800/G800h/G850h), this record is used by the host computer to give orders to the instrument (Yumizen G800/G800h/G850h): list of tests to be run;
- In uploading (Yumizen G800/G800h/G850h -> Host), this record is used by Yumizen G800/G800h/G850h to give the sample identification.

Example:

O|1|01030804||^^^11|R|||||A|||||||Q

Comment: To request a test, the Host has to send the Order Code given in the Yumizen G800/G800h/G850h Test Setup for the specified measurement. If the code differs from these values, the Yumizen G800/G800h/G850h ignores the order.

Description of a Test Order Record:

Paragraph's number of E 1394-97 standard	Character	Field description	Supported	
			Upload (Instrument > Host)	Download (Host > Instrument)
9.4.1	O	Record Type ID= Order record	Yes	Yes
9.4.2	 1	Sequence Number	Yes	Yes
9.4.3	 01030804	Specimen ID = 16 Alphanumeric Character Max.	Yes	Yes
9.4.4		A G800 Specimen and measure position ID	Yes	No

Paragraph's number of E 1394-97 standard	Character	Field description	Supported	
			Upload (Instrument > Host)	Download (Host > Instrument)
9.4.5	 ^ ^ ^ 11	Universal Test ID	Yes	Yes
		Universal Test ID Part 1		
		Universal Test ID Name		
		Universal Test ID Type		
		Manufacturer's or Local Code =ID of the requested test		
		Priority		
9.4.6	 R	R = Routine	Yes	Yes
		S = Stat	Yes	Yes
		A = As soon as possible	No	No
		C = Callback	No	No
		P = Preoperative	No	No
9.4.7		Requested / Ordered Date and Time	Yes	Yes
9.4.8		Specimen collection date and time	Yes	Yes
9.4.9		Collection End Time	Yes	Yes
9.4.10		Collection Volume	Yes	Yes
9.4.11		Collector ID	Yes	Yes
9.4.12	 A	Action Code	Yes	Yes
		A = add requested test to work list		
		N = new request	Yes	Yes
9.4.13		Danger Code	No	No

Paragraph's number of E 1394-97 standard	Character	Field description	Supported	
			Upload (Instrument > Host)	Download (Host > Instrument)
9.4.14		Relevant Clinical Information	No	No
9.4.15		Date and time specimen received	No	No
9.4.16		Specimen descriptor	No	No
9.4.17		Ordering Physician	No	No
9.4.18		Physician Tel Nb	No	No
9.4.19		User Field 1	No	No
9.4.20		User Field 2	No	No
9.4.21		Laboratory Field 1	No	No
9.4.22		Laboratory Field 2	No	No
9.4.23		Date and Time Results reported or last modified	No	No
9.4.24		Instrument Charge to Computer System	No	No
9.4.25		Instrument Section ID	No	No
9.4.26	 Q	Report type Q = answer for the request	Yes	Yes
	<CR>	Carriage return		

Comment: To request a new test, action code A or N will be accepted. Any other action codes will be discarded.

3.6.4. (R)esult Record

Purpose: To transmit Results to the host computer.

Yumizen G800/G800h/G850h implementation example:

```
R|1^PT^11|13,1|s|||F|admin^admin|20130919154743|20130919154743|
G800^H60039R|2|^PT^12|90,1|%|||F|admin^admin|20130919154743|
20130919154743|G800^H60039
```

Comment: The Yumizen G800/G800h/G850h sends the results to the Host with the units specified in the Test Setup, and ignores the requested unit in the Order Record. The results with different units will be sent in separate records. In the case of a measurement error, the cause of the error will be sent in the Comment Record.

Description of a Result Record on Yumizen G800/G800h/G850h:

Paragraph's number of E 1394-97 standard	Character	Field description	Supported	
			Upload (Instrument > Host)	Download (Host > Instrument)
10.1.1	R	Record Type ID= Result Record (52h)	Yes	No
10.1.2	 1	Sequence Number	Yes	No
10.1.3		Universal Test ID	Yes	No
		Universal Test ID Part 1		
	^			
	PT	Universal Test ID Name		
	^			
		Universal Test ID Type		
	11	Manufacturer's or Local Code =ID of the test		
10.1.4	 13,1	Data or Measurement Value = Test result	Yes	No
10.1.5	 s	Units = Unit of the test result	Yes	No
10.1.6		Reference Ranges	No	No

Paragraph's number of E 1394-97 standard	Character	Field description	Supported	
			Upload (Instrument > Host)	Download (Host > Instrument)
10.1.7		Result Abnormal Flags Q - QC is not valid R - rerun D - rediluted W - weak coagulation X - extrapolated result S - sample level check error H - Hemolysis I - Icterus L - Lipemia E - excessive coagulation	Yes	No
10.1.8		Nature of Abnormality Testing	No	No
10.1.9		Result Status		
	F	F = Final results	Yes	No
10.1.9		X = Results cannot be done, request will not be honored	Yes	No
10.1.10		Date of Change in Instrument Normative Values or Units	No	No
10.1.11	 admin ^ admin	Operator Identification	Yes	No
10.1.12	 20130919154743	Date/Time Test Started	Yes	No

Paragraph's number of E 1394-97 standard	Character	Field description	Supported	
			Upload (Instrument > Host)	Download (Host > Instrument)
10.1.13		Date/Time Test Completed		
	20130919154743	Format: yyyymmddhhmmss	Yes	No
		yyyy = year mm = month dd = day hh = hour mm = minutes ss = seconds		
10.1.14	 G800^H60039	Instrument ID Serial Number	Yes	No
	<CR>	Carriage return		

3.6.5. (C)omment Record

Purpose: To transmit comments related to result to the host computer.

Yumizen G800/G800h/G850h implementation example:

C|1||OK^OK|

Description of a Comment Record on Yumizen G800/G800h/G850h:

Paragraph's number of E 1394-97 standard	Character	Field description	Supported	
			Upload (Instrument > Host)	Download (Host > Instrument)
11.1.1	C	Record Type ID= Comment Record (43h)	Yes	No
11.1.2	 1	Sequence Number	Yes	No

Paragraph's number of E 1394-97 standard	Character	Field description	Supported	
			Upload (Instrument > Host)	Download (Host > Instrument)
11.1.3		Source I – Clinical Instrument	Yes	No
11.1.4	 OK ^ OK	Comment text Previous measurement record (R) supplementing text Result status OK = measurement OK ERROR=measurement error DELETED=measurement deleted Measurement error cause OK=no error NO_RESULT=evaluatable result TMIN=coagulation time is shorter than Tmin TMAW= coagulation time is longer than Tmax NO_SAMPLE NO_DILUENT NO_REAGENT NO_DIASORB OVER_INCUB=sample over incubated DELETED=measure deleted SMPID_MISMATCH= sample ID read error RERUN_MAXDIFF=too large difference on rerun measurement	Yes Yes	No No
	<CR>	Carriage return		

3.6.6. Request Information Record, Re(Q)uest

Purpose: For instrument (Yumizen G800/G800h/G850h), to request the working list (test to be run)

Yumizen G800/G800h/G850h implementation example:

```
Q|1|
^01010804\^01020804\^01030804\^01040804\^01050804\^01060804\^01070804\^01080804\^01090804\^01100804\|O\N
```

Comment: In System Settings it can be chosen to request orders for barcode read on only one sample tube, or for the entire rack (10 tubes) in a Q record. In this case by using the repeat delimiter '^' max. 10 results can be requested from Host in one record.

Description of a Request Information Record:

Paragraph's number of E 1394-97 standard	Character	Field description	Supported	
			Upload (Instrument > Host)	Download (Host > Instrument)
12.1.1.	Q	Record Type ID = Request record	Yes	No
12.1.2	 1	Sequence Number	Yes	No
12.1.3		Starting Range ID Number	Yes	No
	^	Computer System Patient ID		
		Specimen ID		
	01010804	= 16 Alphanumeric Characters Max.		
	<CR>	Carriage Return		

3.6.7. Message Terminator Record, (L)ast Record

Purpose: Last record of message.

Yumizen G800/G800h/G850h implementation example:

L|1|N

Description of a Terminator Record:

Paragraph's number of E 1394-97 standard	Character	Field description	Supported	
			Upload (Instrument > Host)	Download (Host > Instrument)
13.1.1	L	Record Type ID = Terminator record	Yes	Yes
13.1.2		Sequence Number	Yes	Yes
13.1.3		Terminator Code		
	N	N = Normal termination	Yes	No
		T = Sender aborted	No	No
		R = Receiver requested abort	No	No
		E = Unknown system error	No	No
		Q = Error in last request for information	No	No
		I = No information available from last query	No	No
	F = Last request for information processed			
	<CR>	Carriage return		

3.7. Test Order Codes

The order codes associated to the test and unit can be found in the Test Setup database. These codes can be used in the Order record for ordering tests.

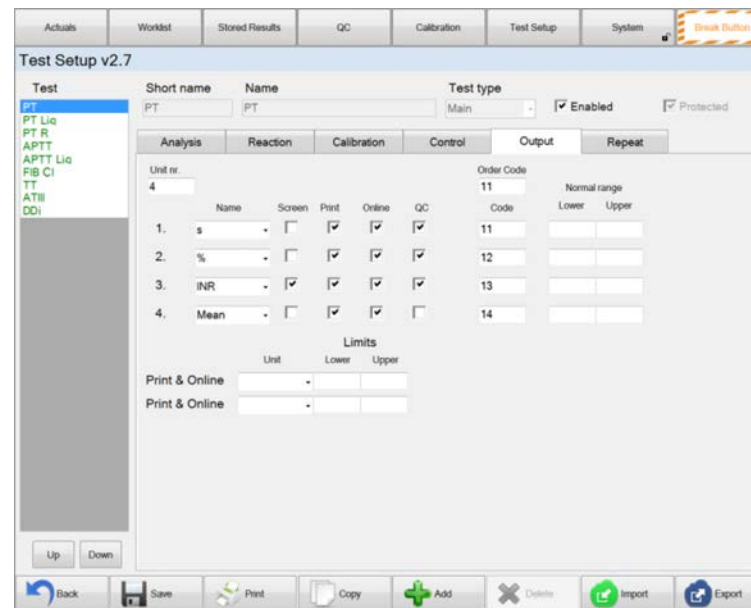

3.8. Example

Data exchange example. The Yumizen G800/G800h/G850h requests test orders for 10 sample tubes from the Host computer:

Yumizen G800/G800h/G850h	Host
<ENQ>	→
	← <ACK>
<STX>1H \^& H60039_1 G800^H60039 HOST P 1394-97 20130919114039<CR> Q 1 ^01010804\^01020804\^01030804\^010 40804\^01050804\^01060804\^0107080 4\^01080804\^01090804\^01100804 ON<CR> L 1 N<CR><ETX>DE<CR><LF>	→
	← <ACK>
<EOT>	→
	← <ENQ>
<ACK>	→
	← <STX>1H \^& <CR> P 1 77777779 TEST SEVENTEEN <CR> O 1 01010804 ^11 R A P Q<CR> O 2 01010804 ^12 R A P Q<CR> P 2 654789321 TEST TWELVE <CR> O 1 01020804 ^11 R A <ETB>A6<CR><LF>
<ACK>	→

Yumizen G800/G800h/G850h	Host
	← <STX>2P Q<CR> O 2 01020804 ^12 R A P Q<CR> P 3 88888888 TEST EIGHT <CR> O 1 01030804 ^11 R A P Q<CR> O 2 01030804 ^12 R A P Q<CR> P 4 11111111 TEST ONE <ETB>DC<CR><LF>
<ACK>	→
	← <STX>3 <CR> O 1 01040804 ^11 R A P Q<CR> O 2 01040804 ^12 R A P Q<CR> P 5 99999999 TEST NINE <CR> O 1 01050804 ^11 R A P Q<CR> O 2 01050804 ^12 R A P <ETB>D6<CR><LF>
<ACK>	→
	← <STX>4Q<CR>P 6 88888889 TEST EIGHTEEN <CR> O 1 01060804 ^11 R A P Q<CR> O 2 01060804 ^12 R A P Q<CR> P 7 321654987 TEST ELEVEN <CR> O 1 01070804 ^11 R A P Q<CR> O 2 <ETB>F3<CR><LF>
<ACK>	→

Yumizen G800/G800h/G850h	Host
←	<STX>5 01070804 ^12 R A P Q<CR> P 8 321654987 TEST ELEVEN <CR> O 1 01080804 ^11 R A P Q<CR> O 2 01080804 ^12 R A P Q<CR> P 9 222222220 TEST TWENTY <CR> O 1 0109 <ETB>E3<CR><LF>
<ACK>	→
←	<STX>60804 ^11 R A P Q<CR> O 2 01090804 ^12 R A P Q<CR> P 10 321654987 TEST ELEVEN <CR> O 1 01100804 ^11 R A P Q<CR> O 2 01100804 ^12 R A P Q<CR> L 1 F<CR> <ETX>BB<CR><LF>
<ACK>	→
←	<EOT>

Send measurement results to Host computer:

Yumizen G800/G800h/G850h	Host
<ENQ>	→
←	<ACK>

Yumizen G800/G800h/G850h	Host
←	<STX>1H ^& H60039_1 G800^H60039 HOST P 1394-97 20130920101318<CR> P 1 321654987 TEST ELEVEN 00010101 <CR> O 1 01100804 15^M3 ^11 S 20140831213033 P F<CR> R 1 ^Dia-PT^11 14,7 s N F ^ 20140831212627 20140831213033 <ETB>B1<CR><LF>
<ACK>	→
←	<STX>2G800^H60039<CR> C 1 OK^OK <CR>R 2 ^Dia-PT^12 74,5% N F ^ 20140831212627 20140831213033 G800^H60039<CR> C 1 OK^OK <CR> R 3 ^Dia-PT^13 1,19 INR N F ^ 20140831212627 20140831213033 G800^H60039<CR> C 1 OK^OK <CR> L 1 N<CR> <ETX>32<CR><LF>
<ACK>	→
<EOT>	→

