

OUTPUT FORMATS

ABX **Pentra 60**
ABX **Pentra 60** C+
Pentra ES 60

RAA039BEN

Table of Contents

- > Introduction, page 3
- > Format compatibility, page 4
- > Physical connection (RS232), page 5
- > ASTM Format (ABX Pentra 60 C+ / Pentra ES 60), page 6
- > ABX Format, page 19
- > ARGOS Format, page 33



Introduction

ASTM Format is recommended by HORIBA Medical for every new connection development. ABX Format is currently supported to be compliant with existing connections, but will not be supported on future generation of instrument. Argos Format is no longer supported on new system generation.

Different protocols can be used on HORIBA Medical instrument, a connection between a computer (host) and an HORIBA Medical instrument can be performed when the protocol, the format description and the connection mode have been properly set up.

Table 1: Definitions

Term	Definition
<ACK>	Acknowledgment (ASCII Decimal 6)
[C1]	The most significant character of Checksum
[C2]	The least significant character of Checksum
[DATA]	The data contents of the record
<ENQ>	Inquire (ASCII Decimal 5)
<ETB>	End of Transmission Block (ASCII Decimal 23). For use only when a single record is too large to fit into one frame.
<ETX>	End of Text (ASCII Decimal 3). Required at the end of each record.
[frame number]	Single digit frame number "0" to "7", starts with "1".
<LF>	Line Feed (ASCII Decimal 10).
<NAK>	Negative Acknowledgment (ASCII Decimal 21).
<STX>	Start of Frame (ASCII Decimal 2).
Communications packet	All framing required for transmission of data. This framing includes: <STX>[frame number][DATA] [<ETB> or <ETX>][C1][C2] <LF>
Component Field	One of several related pieces of information within a field.
Field	A specific location within a record for a piece of information, indicated by a field delimiter and position.

Table 1: Definitions

Term	Definition
Frame	A complete communications packet.
LIS	Laboratory Information System
Message	A collection of related information; a group of records that begins with a «Header» record and ends with a «Terminator» record. A single record could theoretically constitute a message, but within this context, a message always contains multiple records.
<EOT>	End of Transmission (ASCII decimal 4)
<CR>	Carriage Return (ASCII decimal 13)
Record	In reference to the low level protocol, a record is the message data (shown as [DATA]) as described within the communications packet. If the data is longer than 240 characters, then it must be split into two (or more) parts and sent in two (or more) communications packets. The intermediate packet uses the <ETB> character, and the ending packet uses the <ETX> character. No single communications packet contains more than one record. In reference to the message layer, a record can be one of the following codes: H (header), P (patient), O (order), R (result), L (terminator), C (comment).
Session	A total unit of communication activity used in this standard to indicate the events starting with the Establishment phase and ending with the Termination phase.
Test	A determination of a single analyte or a combination of values from other determinations or observations from which a variable or gradable result is derived.



Format compatibility

Table 2: Format compatibility according to HORIBA Medical analyzers & types of analyses

Analysis types	ABX Pentra 60			ABX Pentra 60C+ / Pentra ES 60		
	ABX	ASTM	Argos	ABX	ASTM	Argos
Receive Orders				X	X	X
CBC	X		X	X	X	X
DIF (CBC+DIF)	X		X	X	X	X



Physical connection (RS232)

Instrument RS DB9

- GND: ground
- TXD: transmission
- RXD: reception

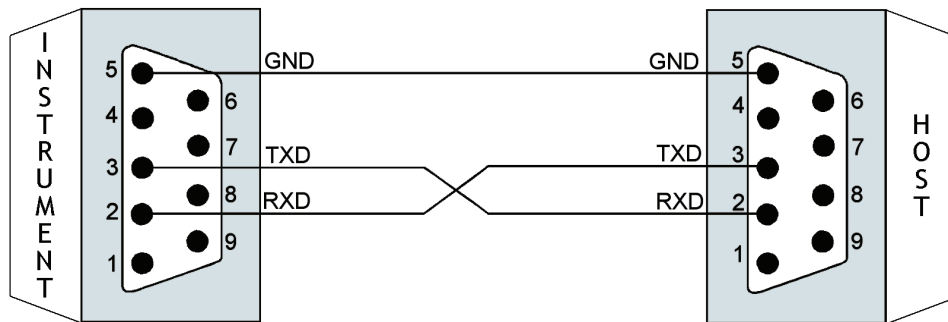

ASTM Format (ABX Pentra 60 C+ / Pentra ES 60)

HORIBA Medical analyzers format responds to the ASTM spec. E-1381 & E-1394:

- E-1381: Standard specification for Low Level protocol to transfer messages between clinical and laboratory instruments and computer systems.
- E-1394: Standard specification for transferring Information between clinical and laboratory instruments and computer systems.

1. Connection specifications (ASTM E-1381)

1.1. Hardware and software characteristics

Default format for emitted character is 1 bit start, 8 data bits, No parity, 1 bit stop.
Default communication speed is 38400 bauds.

Hardware setting of the interface: Plug A&B are DB9 male plugs.

1.2. Output data characteristics

Characters: ASCII
Maximum message length: 247 characters.
Analyzer manages Xon/Xoff protocol.

1.3. Communication protocol

Table 3: Standard control characters

Control String	Hexadecimal value
<ENQ>	\$05
<ACK>	\$06
<NAK>	\$15

Table 3: Standard control characters

Control String	Hexadecimal value
<STX>	\$02
<ETX>	\$03
<CR>	\$0D
<LF>	\$0A
<EOT>	\$04

1.3.1. Instrument\Host connexion

Table 4: Typical discussion between Instrument and Host

Instrument	< >	Host
<ENQ>	>	
	<	<ACK>
<STX>1...Data...<CR><ETX>xx<CR><LF>	>	
	<	<ACK>
<STX>2...Data...<CR><ETX>xx<CR><LF>	>	
	<	<ACK>
<EOT>	>	

Table 5: Typical discussion between Host and Instrument

Instrument	< >	Host
	<	<ENQ>
<ACK>	>	
	<	<STX>1...Data...<CR><ETX>xx<CR><LF>
<ACK>	>	



Table 5: Typical discussion between Host and Instrument

Instrument	<>	Host
	<	<STX>2...Data...<CR><ETX>xx<CR><LF>
<ACK>	>	
	<	<EOT>

1.4. Management of errors

1.4.1. During Instrument transmission

During a single result transmission by the instrument, if the host lost the transmission (Time-Out or EOT) the full message is transmitted again after a parametrable delay (10s by default).

In case of long files with several results, the re-transmission is done from the result lost to the end.

After 6 consecutive NAKs detected the sent file is deferred to later transmission.

1.4.2. During Host transmission

According to E-1381 protocol, error management of Time-out, Checksum and frame number, in case of non-respect of these norms, returns NAK (or communication is halted). In case of transmission of long files (Worklist upload for example), files previously transmitted before transmission error are interpreted and managed by the instrument, others are not used..

According to E-1394 protocol, all Orders without «Sample ID» or with «Sample ID» superiors to 16 characters, are not interpreted by the instrument.

In case of «Patient ID» field empty or too long, but with a correct «Sample ID», the Order is interpreted, but result returns with an auto-patient ID set by the instrument.

All other too long fields are cut to fit to ASTM field specified length.

1.4.3. Discussion with conflict between Instrument and Host

Number of transmission if negative answer (NAK): 6
 Timeout if no response: 15s (Automatic disconnection max. time)
 Retry timeout: Variable < 30s
 Special timing: None
 Description of other specific treatments: None

In case of ENQ\ENQ conflict analyzer waits 2s and tries emission again.

Analyzer is master in case of conflict.

Table 6: Discussion with conflict between Instrument and Host

Instrument	<>	Host
<ENQ>	>	
	<	<ENQ>
Wait 2 second...		
<ENQ>	>	
	<	<ACK>
<STX>1...Data...<CR><ETX>xx<CR><LF>	>	
	<	<ACK>
<STX>2...Data...<CR><ETX>xx<CR><LF>	>	
	<	<ACK>
<EOT>	>	



1.4.4. Defect packet during discussion between Instrument and Host

Table 7: Defect packet during discussion between Instrument and Host

Instrument	<>	Host
<ENQ>	>	
	<	<ACK>
<STX>1...Data...<CR><ETX>xx<CR><LF>	>	
	<	<NAK>
<STX>1...Data...<CR><ETX>xx<CR><LF>	>	
	<	<ACK>
<STX>2...Data...<CR><ETX>xx<CR><LF>	>	
	<	<ACK>
<EOT>	>	

1.5. ASTM Data frame format

A sequential number located after the <STX> character is inserted into each Data frame. Frame number is set to 1 when transfer phase is initialized and is incremented by 1 for each frame up to 7 and then returns to 0.

Frame number is to permit receiver to distinguish between new and retransmitted frame, in case of retransmitted frame (after a <NAK> response from Host), frame number is not incremented: <STX>1...Data...<CR><ETX>xx<CR><LF>

Table 8: Frame format

ASTM field	Definition	Transmitted data	# of bytes	Comments
0	STX	\$02	1	
1	Frame number	1 to 7, 0, ...	1	Frame number is set to 1 and incremented by 1 for each frame up to 7 and then returns to 0
2	Data message		240 max.	Header, Patient, Order, Result & Comment messages
3	End of data message ETX if end frame		1	
4	Checksum		2	
5	CRLF	\$0D \$0A	2	

1.5.1. Frame checksum

According to ASTM E-1381 frame checksum (<STX>1...Data...<CR><ETX>xx<CR><LF>) is defined as modulo 256 of ASCII values sum between <STX> not included and <ETX> included characters: 1...Data...<CR><ETX>



2. Records general format specifications (ASTM E-1394)

Data frames encapsulate Records defined by ASTM E-1394 norm, Records themselves encapsulate ASTM fields.

Example of record inside Data frame: <STX>1...Data...<CR><ETX>xx<CR><LF>

<STX>1H|\^&|||HostSimulator|||||ABX|P|E1394-97|20020705144108<CR><ETX>D3<CR><LF>

Table 9: ASTM Records

Record ID	ASTM Definition	P60C+ / PES60
H	Header	X
P	Patient	X
O	Order	X
R	Result	X
C	Comment	X
L	Terminator record	X

2.1. Structure of Records

2.1.1. Structure of records for Order transmission

- H (Header)
- P (Patient)
- C (Patient Comments) Optional
- ..O (Order)
- ..C (Order Comments) Optional
- L (Terminator)

The transmission of an Order without Patient record is not allowed, but Patient record can be empty. Example: <STX>2P|1<CR><ETX>BB<CR><LF>

2.1.2. Instrument Patient file modification by Host

- H (Header)
- P (Patient)
- C (Patient Comments) Optional
- L (Terminator)

2.1.3. Structure of records for Result transmission

- H (Header)
- P (Patient)
- C (Patient Comments) Optional
- ..O (Order)
- ..C (Order Comments) Optional
- ..C (Run Alarms) Optional
- R (Result)
- C (Flag Result) Optional
- R (Result)
- C (Flag Result) Optional
-
-
- R (Result)
- C (Flag Result) Optional
- L (Terminator)

2.2. Description of Records

- Only fields described with their specified length are used by HORIBA Medical instruments.
- Length of field can be less than maximum value but must not be more.
- Only «Sample ID» and «Test» fields from Order record must be informed, all other fields are optionals.



- Delimiter must be used even if field is free.
- Delimiters inside records are separate by «|» (ASCII \$7C).
- Delimiters inside fields are separate by «^» (ASCII \$5E).

2.2.1. Header record

Table 10: Header record fields

ASTM field	Definition	Transmitted data	Field max. length	
			P60C+ / PES60	
7.1.1	Record Type	H	1	
7.1.2	Delimiters definition	idem standard: Field delimiter \ Repeat delimiter ^ Component delimiter & Escape delimiter	4	
7.1.3	Message Control ID			
7.1.4	Access Password			
7.1.5	Sender Name	ABX	3	
7.1.6	Sender Address			
7.1.7	Reserved			
7.1.8	Sender Telephone Nb			
7.1.9	Characteristics of Sender			
7.1.10	Receiver ID			
7.1.11	Comments or Special Instructions			
7.1.12	Processing ID	P	1	
7.1.13	ASTM Version Nb	E 1394-97	9	
7.1.14	Date and Time of message	YYYYMMDDHHMMSS	14	

2.2.2. Patient record

Table 11: Patient record fields

ASTM field	Definition	Transmitted data	Field max. length	
			P60C+ / PES60	
8.1.1	Record Type	P	1	
8.1.2	Sequence Nb	1, 2, ...	2	
8.1.3	Practice Assigned Patient ID			
8.1.4	Laboratory Assigned Patient ID	Patient Id	30	
8.1.5	Patient ID No 3			
8.1.6	Patient Name	Name^First name	30	
8.1.7	Mother's Maiden Name			
8.1.8	Birthdate	YYYYMMDD	8	
8.1.9	Patient Sex	M, F or U (see Note 1)	1	
8.1.10	Patient Race-Ethnic Origin			
8.1.11	Patient Address			
8.1.12	Reserved			
8.1.13	Patient Telephone Nb			
8.1.14	Attending Physician ID	Text	15	
8.1.15	Special Field 1			
8.1.16	Special Field 2			
8.1.17	Patient Height			
8.1.18	Patient Weight			
8.1.19	Patient's Known or Suspected Diagnosis			
8.1.20	Patient Active Medication			
8.1.21	Patient's Diet			
8.1.22	Practice Field 1			



Table 11: Patient record fields

ASTM field	Definition	Transmitted data	Field max. length		
			P60C+ / PES60		
8.1.23	Practice Field 2				
8.1.24	Admission and Discharge Dates				
8.1.25	Admission Status				
8.1.26	Location	Text	16		
8.1.27	Nature of Alternative Diagnostic Code and Classifiers				
8.1.28	Nature of Alternative Diagnostic Code and Classifiers				
8.1.29	Patient Religion				
8.1.30	Marital status				
8.1.31	Isolation Status				
8.1.32	Language				
8.1.33	Hospital Service				
8.1.34	Hospital Institution				
8.1.35	Dosage Category				

2.2.3. Order record

Table 12: Order record fields

ASTM field	Definition	Transmitted data	Field max. length		
			P60C+ / PES60		
9.4.1	Record Type	O	1		
9.4.2	Sequence Nb	1, 2, ...	2		
9.4.3	Sample ID		16		
9.4.4	Instrument Specimen ID				
9.4.5	Universal Test ID	^^^Test name (CBC or DIF) (see Note 2)	6		
9.4.6	Priority				
9.4.7	Requested/Ordered Date and Time				
9.4.8	Specimen Collection Date and Time	YYYYMMDDHHMMSS	14		
9.4.9	Collection End Time	YYYYMMDDHHMMSS	14		
9.4.10	Collection Volume				
9.4.11	Collector ID				
9.4.12	Action Code				
9.4.13	Danger Code				
9.4.14	Relevant Clinical Information				
9.4.15	Date/Time Specimen Received				
9.4.16	Specimen Descriptor	Text	20		
9.4.17	Ordering Physician				
9.4.18	Physician Tel Nb				
9.4.19	User Field 1				
9.4.20	User Field 2				
9.4.21	Laboratory Field 1				



• NOTE 1:

M: Male, F: Female, U: Unspecified (If instrument receives an empty field (blank) it uses Unspecified type).

Table 12: Order record fields

ASTM field	Definition	Transmitted data	Field max. length		
			P60C+ / PES60		
9.4.22	Laboratory Field 2				
9.4.23	Date and Time Results reported or last modified				
9.4.24	Instrument Charge to Computer System				
9.4.25	Instrument Section ID				
9.4.26	Report Types			1	
9.4.27	Reserved				
9.4.28	Location or Ward of Specimen Collection				
9.4.29	Nosocomial Infection Flag				
9.4.30	Specimen Service				
9.4.31	Specimen institution				



• **NOTE 2:**
Field 9.4.5 «Universal test ID» must be necessarily filled by the type of analysis requested (CBC or DIF, See Special characteristics for HORIBA Medical data, page 13).

2.2.4. Result record

Table 13: Result record fields

ASTM field	Definition	Transmitted data	Field max. length		
			P60C+ / PES60		
10.1.1	Record Type	R		1	
10.1.2	Sequence Nb	1, 2, ...		2	
10.1.3	Universel Test ID			15	
10.1.4	Data or Measurement Value	Test result (See Special characteristics for HORIBA Medical data, page 13)	^^^PARAM.^LOINC		
10.1.5	Unit or Set of units	1, 2, 3 or 4			
10.1.6	Reference Range				
10.1.7	Result Abnormal Flag	Analytical flag L,H,LL,HH		2	
10.1.8	Nature of Abnormality Testing				
10.1.9	Result Status	W: suspicion N: rejected result F: final result		1	
10.1.10	Date of Change in Normative Values or Units				
10.1.11	Operator Identification				
10.1.12	Date/Time Test Starting				
10.1.13	Date/Time Test Completed	YYYYMMDDHHMMSS		14	
10.1.14	Instrument Identification				

2.2.5. Comment record

Table 14: Comments record fields

ASTM field	Definition	Transmitted data	Field max. length		
			P60C+ / PES60		
11.1.1	Record Type	C		1	
11.1.2	Sequence Nb	1, 2, ...		2	
11.1.3	Comment Source	I clinical instrument system		1	
11.1.4	Comment Text	Text (See Table Analytical alarms, See Table Analyzer alarms, See Table Suspected pathologies)		100	
11.1.5	Comment Type	G: Free text I: Instrument flag comment L: Comment from host (Patient order)		1	

2.2.6. Terminator record

Table 15: Terminator record

ASTM field	Definition	Transmitted data	Field max. length		
			P60C+ / PES60		
13.1.1	Record type	L		1	
13.1.2	Sequence number	1		1	
13.1.3	Termination code	N: Normal		1	

3. Special characteristics for HORIBA Medical data

3.1. CBC Data presentation

Table 16: CBC Data presentation

Parameter	English code	LOINC	Standard	SI	mmol/l	JAPAN
White Blood Cell	WBC	804-5	10 ³ /mm ³	10 ⁹ /L	10 ⁹ /L	10 ² /mm ³
Red Blood Cell	RBC	789-9	10 ⁶ /mm ³	10 ¹² /L	10 ¹² /L	10 ⁴ /mm ³
Hemoglobin	HGB	717-9	g/dL	g/L	mmol/L	g/dL
Hematocrit	HCT	4544-3	%	L/L	L/L	%
Mean Corpuscular Volume	MCV	787-2	μm ³	fL	fL	μm ³
Mean Corpuscular Hemoglobin	MCH	785-6	pg	pg	fmol	pg
Mean Corpuscular Hemoglobin Concentration	MCHC	786-4	g/dL	g/L	mmol/L	g/dL
Red Distribution Width	RDW	788-0	%	%	%	%
Platelets	PLT	777-3	10 ³ /mm ³	10 ⁹ /L	10 ⁹ /L	10 ³ /mm ³
Mean Platelet Volume	MPV	776-5	μm ³	fL	fL	μm ³
Plateletcrit	PCT	X-PCT	%	10 ¹² /L	10 ¹² /L	%
Platelet Distribution Width	PDW	X-PDW	%	%	%	%



3.2. DIF Data presentation

Table 17: DIF Data presentation

Parameter	English code	LOINC	Standard	SI	mmol/l	JAPAN
White Blood Cell	WBC	804-5	10 ³ /mm ³	10 ⁹ /L	10 ⁹ /L	10 ² /mm ³
Lymphocytes #	LYM#	731-0	10 ³ /mm ³	10 ⁹ /L	10 ⁹ /L	10 ² /mm ³
Lymphocytes %	LYM%	736-9	%	%	%	%
Monocytes #	MON#	742-7	10 ³ /mm ³	10 ⁹ /L	10 ⁹ /L	10 ² /mm ³
Monocytes %	MON%	744-3	%	%	%	%
Neutrophils #	NEU#	751-8	10 ³ /mm ³	10 ⁹ /L	10 ⁹ /L	10 ² /mm ³
Neutrophils %	NEU%	770-8	%	%	%	%
Eosinophils #	EOS#	711-2	10 ³ /mm ³	10 ⁹ /L	10 ⁹ /L	10 ² /mm ³
Eosinophils %	EOS%	713-8	%	%	%	%
Basophils #	BAS#	704-7	10 ³ /mm ³	10 ⁹ /L	10 ⁹ /L	10 ² /mm ³
Basophils %	BAS%	706-2	%	%	%	%
Atypical Lymphocytes #	ALY#	733-6	10 ³ /mm ³	10 ⁹ /L	10 ⁹ /L	10 ² /mm ³
Atypical Lymphocytes %	ALY%	735-1	%	%	%	%
Large Immature Cell #	LIC#	X-LIC	10 ³ /mm ³	10 ⁹ /L	10 ⁹ /L	10 ² /mm ³
Large Immature Cell %	LIC%	11117-9	%	%	%	%
Red Blood Cell	RBC	789-9	10 ⁶ /mm ³	10 ¹² /L	10 ¹² /L	10 ⁴ /mm ³
Hemoglobin	HGB	717-9	g/dL	g/L	mmol/L	g/dL
Hematocrit	HCT	4544-3	%	L/L	L/L	%
Mean Corpuscular Volume	MCV	787-2	μm ³	fL	fL	μm ³
Mean Corpuscular Hemoglobin	MCH	785-6	pg	pg	fmol	pg

Table 17: DIF Data presentation

Parameter	English code	LOINC	Standard	SI	mmol/l	JAPAN
Mean Corpuscular Hemoglobin Concentration	MCHC	786-4	g/dL	g/L	mmol/L	g/dL
Red Distribution Width	RDW	788-0	%	%	%	%
Platelets	PLT	777-3	10 ³ /mm ³	10 ⁹ /L	10 ⁹ /L	10 ³ /mm ³
Mean Platelet Volume	MPV	776-5	μm ³	fL	fL	μm ³
Plateletcrit	PCT	X-PCT	%	10 ¹² /L	10 ¹² /L	%
Platelet Distribution Width	PDW	X-PDW	%	%	%	%

3.3. Alarms and Pathologies

ASTM specification reserved no field for pathologies. Pathology messages are sent through the comment record.

Each different type of alarm is transmitted through one different Comment record, a «i» (letter «i» in upper case) flag ended the Comment record and shows a warning from the instrument.

Example:

- H|\^&|||ABX|||||P|E1394-97|20010413105547
- P|1||||SANTOS^JeanPhilippe||||||FRICH Philippe
- ..O|1|0002|7|^^^DIF|||||||F
- R|1|^^^WBC^804-5|5.26|10e3/mm3||L||F
- C|1||^L1^LL^NL^LL1||

3.3.1. Analytical alarms

Analytical alarms are transmitted through one Comment record located after the corresponding Result record.



Table 18: Analytical alarms

Alarm type	All instruments	See note
ALARM_WBC	MB, CO, NE, LL, NL, MN, LN, RM, RN, NO, LB, BASO, Baso+, L1, MP, LI1, LMNE+, LMNE-	
ALARM_RBC	Mi, Ma	3
ALARM_PLT	PC, MC, SC	3



- NOTE 3:
«Mi» stands for MIC alarm, «Ma» stands for MAC alarm, «PC» stands for SCL alarm, «MC» stands for MIC alarm and «SC» stands for SCH alarm.

3.3.2. Analyzer alarms

Analyzer's alarms are transmitted through the Comment record located after the Order record.

Table 19: Analyzer alarms

Alarm type	All instruments
ALARM_ANALYSER	XB, XR, QC, WESTGARD, STARTUP FAILED, STARTUP NOTDONE, STARTUP NOTEFFECTIVE, FOR INVESTIGATIONAL USE ONLY

3.3.3. Suspected pathologies

Suspected pathologies are transmitted through one Comment record located after corresponding Result record. If several pathologies are suspected, they are separated by the component delimiter.

Table 20: Suspected pathologies

Populations	Messages
WBC	LEUCOCYTOSIS
	LEUCOPENIA
	LYMPHOCYTOSIS
	LYMPHOPENIA
	NEUTROPHILIA
	NEUTROPENIA
	EOSINOPHILIA
	MYELEMIA
	LARGE IMMATURE CELL
	ATYPICAL LYMPHOCYTE
	LEFT SHIFT
	NRBCs
	MONOCYTOSIS
	BASOPHILIA
BLASTS	
PANCYTOPENIA	
WBC INTERPRETATION IMPOSSIBLE	
RBC	ANEMIA
	ANISOCYTOSIS
	MICROCYTES
	MICROCYTES+
	MICROCYTES++
	MACROCYTES
	MICROCYTOSIS
MACROCYTOSIS	



Table 20: Suspected pathologies

Populations	Messages
	HYPOCHROMIA
	COLD AGGLUTININES
	PANCYTOPENIA
	RBC INTERPRETATION IMPOSSIBLE
PLT	THROMBOCYTOSIS
	THROMBOPENIA
	PLATELET AGGREGATS
	SMALL CELLS
	MICROCYTES
	SCHIZOCYTES
	MACROPLATELETS
	PANCYTOPENIA
	PLT INTERPRETATION IMPOSSIBLE

3.3.4. Suspicion and Reject

When one result is suspected abnormal or false, that means result is not reliable, the instrument returns a flag in field 10.1.9 (See Table 13, “Result record fields”, page 12).

3.3.5. Normal and Panic ranges

Flags when result exceeds Normal or Panic ranges are transmitted through field 10.1.7, they should be compared, to get a full result information, to the ranges set by the user, these low and high limits can be transmitted through field 10.1.6 (See Table 13, “Result record fields”, page 12).

4. Example of data frame

4.1. Example of Order sent by Host

- Patient ID: PID12345
- Patient Name: LASTNAME, FIRSTNAME
- Birthdate: 23/12/1964
- Prescripator: Prescripator
- Department: Location
- Sample ID (mandatory field): SID007
- Test (mandatory field): CBC

Table 21: Example of Order sent by Host

Host
Instrument
<ENQ>
<ACK>
<STX>1H ^& ABX P 1394-97 20031202102713<CR><ETX>06<CR><LF>
<ACK>
<STX>2P 1 PID12345 LASTNAME^FIRSTNAME 19641223 M Prescripator Location<CR><ETX>D6<CR><LF>
<ACK>
<STX>3C 1 Patient Comment<CR><ETX>3C<CR><LF>
<ACK>
<STX>4O 1 SID007 ^C CBC R A<CR><ETX>04<CR><LF>
<ACK>
<STX>5C 1 Order Comment<CR><ETX>65<CR><LF>
<ACK>
<STX>6L 1 N<CR><ETX>09<CR><LF>
<ACK>
<EOT>



4.2. Example of Result sent by instrument

Table 22: Example of Result sent by instrument

Instrument
Host
<ENQ>
<ACK>
<STX>1H ^& ABX P E1394-97 20020725100331<CR><ETX>4D<CR><LF>
<ACK>
<STX>2P 1 AUTO_PID1381 CATHELIN 19260813<CR><ETX>4F<CR><LF>
<ACK>
<STX>3O 1 25028 ^DIF F<CR><ETX>13<CR><LF>
<ACK>
<STX>4R 1 ^WBC^804-5 3.45 10e3/mm3 LL F<CR><ETX>D6<CR><LF>
<ACK>
<STX>5C 1 LEUCOPENIA^LYMPHOPENIA^NEUTROPENIA^EOSINOPHILIA^MONOCYTOSIS <CR><ETX>C4<CR><LF>
<ACK>
<STX>6R 2 ^LYM#^731-0 0.78 LL F<CR><ETX>DA<CR><LF>
<ACK>
<STX>7R 3 ^LYM%^736-9 22.50 % LL F<CR><ETX>3B<CR><LF>
<ACK>
<STX>0R 4 ^MON#^742-7 0.42 F<CR><ETX>36<CR><LF>
<ACK>
<STX>1R 5 ^MON%^744-3 12.20 % HH F<CR><ETX>1C<CR><LF>
<ACK>
<STX>2R 6 ^NEU#^751-8 1.99 LL F<CR><ETX>DE<CR><LF>
<ACK>
<STX>3R 7 ^NEU%^770-8 57.70 % F<CR><ETX>A0<CR><LF>

Table 22: Example of Result sent by instrument

<ACK>
<STX>4R 8 ^EOS#^711-2 0.26 F<CR><ETX>34<CR><LF>
<ACK>
<STX>5R 9 ^EOS%^713-8 7.40 % HH F<CR><ETX>F8<CR><LF>
<ACK>
<STX>6R 10 ^BAS#^704-7 0.01 F<CR><ETX>4E<CR><LF>
<ACK>
<STX>7R 11 ^BAS%^706-2 0.20 % F<CR><ETX>75<CR><LF>
<ACK>
<STX>0R 12 ^ALY#^733-6 0.07 F<CR><ETX>61<CR><LF>
<ACK>
<STX>1R 13 ^ALY%^735-1 1.89 % F<CR><ETX>92<CR><LF>
<ACK>
<STX>2R 14 ^LIC#^X-LIC 0.03 F<CR><ETX>B0<CR><LF>
<ACK>
<STX>3R 15 ^LIC%^11117-9 0.80 % F<CR><ETX>E2<CR><LF>
<ACK>
<STX>4R 16 ^RBC^789-9 4.43 10e6/mm3 F<CR><ETX>81<CR><LF>
<ACK>
<STX>5R 17 ^HGB^717-9 13.47 g/dl F<CR><ETX>D6<CR><LF>
<ACK>
<STX>6R 18 ^HCT^4544-3 38.95 % F<CR><ETX>DB<CR><LF>
<ACK>
<STX>7R 19 ^MCV^787-2 87.94 um3 F<CR><ETX>EB<CR><LF>
<ACK>
<STX>0R 20 ^MCH^785-6 30.40 pg F<CR><ETX>3D<CR><LF>
<ACK>
<STX>1R 21 ^MCHC^786-4 34.57 g/dl F<CR><ETX>1C<CR><LF>



Table 22: Example of Result sent by instrument

<ACK>
<STX>2R 22 ^^^RDW^788-0 13.49 % F<CR><ETX>AB<CR><LF>
<ACK>
<STX>3R 23 ^^^PLT^777-3 186.74 10e3/mm3 F<CR><ETX>FA<CR><LF>
<ACK>
<STX>4R 24 ^^^MPV^776-5 8.45 µm3 F<CR><ETX>B7<CR><LF>
<ACK>
<STX>5R 25 ^^^PCT^X-PCT 0.16 % F<CR><ETX>D9<CR><LF>
<ACK>
<STX>6R 26 ^^^PDW^X-PDW 14.50 % F<CR><ETX>16<CR><LF>
<ACK>
<STX>7L 1 N<CR><ETX>40<CR><LF>
<ACK>
<EOT>



ABX Format

ASTM Format is recommended by HORIBA Medical for every new connection development. ABX Format is currently supported to be compliant with earlier instruments or existing connections.

1. Overview

- ABX format supports unidirectionnal or bidirectionnal connections.
- ABX format can have a different numbers of fields according to the transmitted items set up by the user (results, curves, flags, etc...) or to the type of cycle.
- Fields sequence is not fixed.
- The result identifier is different according to the type of result: patient result («RESULT»), re-run result (RES-RR), QC result (QC-RES) etc... (See Table 4, “Data transmitted by the host to the analyzer”, page 22).
- ABX Pentra 60 cannot be programmed in bidirectionnal mode.

2. Protocol description

2.1. Unidirectionnal mode

2.1.1. Typical unidirectionnal transmission from Instrument to Host

Table 23: Typical unidirectionnal transmission from Instrument to Host

Instrument	< >	Host	Comment
<STX> + RESULT + <ETX>	>		

2.1.2. Typical unidirectionnal transmission from Instrument to Host with «SOH»\»EOT»

«SOH»\»EOT» option must be enabled on the instrument.

Table 24: Typical unidirectionnal transmission with «SOH»\»EOT» from Instrument to Host

Instrument	< >	Host	Comment
<SOH>	>		Instrument takes the Line
<STX> + RESULT + <ETX>	>		
	.		
	.		
	.		
<STX> + RESULT + <ETX>	>		
<EOT>	>		Instrument frees the Line



2.2. Bidirectionnal mode

2.2.1. Typical bidirectionnal transmission from Host to Instrument

Table 25: Typical transmission from Host to Instrument

Host	< >	Instrument	Comment
<SOH>	>		Host takes the Line
	<	<ENQ>	
<STX> + FILE + <ETX>	>		
	<	<ACK>	
	.		
	.		
	.		
<STX> + END + <ETX>	>		Host frees the Line
	<	<ACK>	

2.2.2. Typical bidirectionnal transmission from Instrument to Host

Table 26: Typical transmission from Instrument to Host

Instrument	< >	Host	Comment
<SOH>	>		Instrument takes the Line
	<	<ENQ>	
<STX> + RESULT + <ETX>	>		
	<	<ACK>	
	.		
	.		

Table 26: Typical transmission from Instrument to Host

Instrument	< >	Host	Comment
	.		
<STX> + END + <ETX>	>		Instrument frees the Line
	<	<ACK>	

2.3. Conflict management

Number of transmission if negative answer (NAK): 1
 Timeout: 15s

In case of SOH/SOH conflict, priority is given to Host. After an adjustable delay (8s by default) and if Host does not re-sent a SOH, instrument tries to send SOH again until timeout. This is done until automatic disconnection max time is reached.



3. Message structure

3.1. Lines structure

HEADER:

- STX
- Size + carriage return (Size: 5 bytes representing the total amount of the data except STX and ETX).
- Identifier followed by a Load Type + carriage return (Load: 8 character string preceded by a blank indicating the type of data).

VARIABLE PART:

- Identifier followed by the Information associated to the Load Type + carriage return (Identifier: 1 byte moving about \$21 to \$FF, it describes the information type which follows this indicator, always followed by a blank character \$20).
- Remainder of the other Identifiers and Information associated to the Load Type + carriage returns.
- Other Load Type blocs + Associated Information

POST-HEADER:

- Format Version Number
- Identifier followed by CheckSum + carriage return (CheckSum: Sum modulo 65536 of all characters except ETX, STX and all information about checksum (identifier - space - checksum - carriage return) in the hexadecimal format on 4 bytes, preceded by a blank character \$20).
- ETX

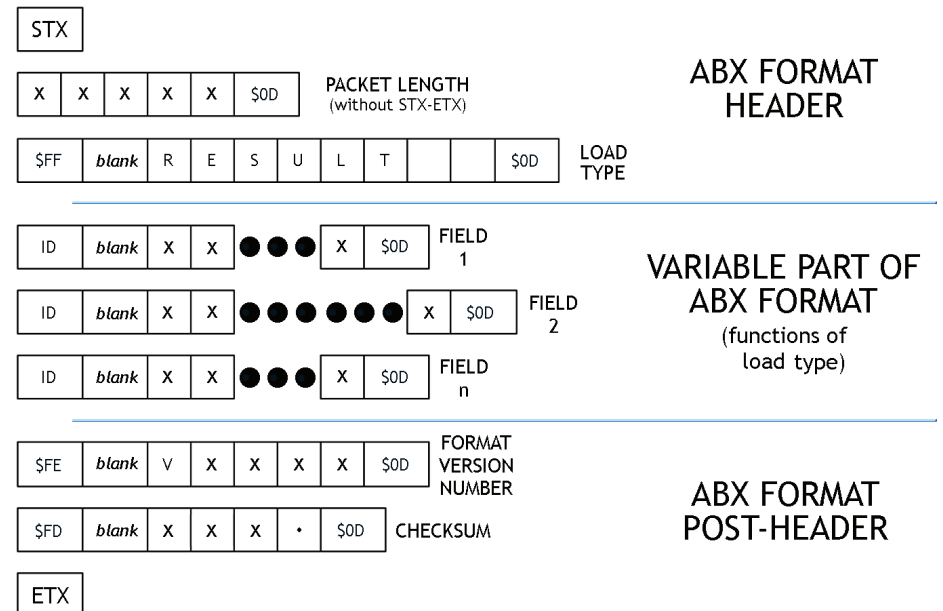

Diag.1: ABX format line structure

3.2. Control characters

Table 27: Standard control characters

Control String	Hexadecimal value
<ENQ>	\$05
<ACK>	\$06
<NAK>	\$15
<STX>	\$02
<ETX>	\$03



Table 27: Standard control characters

Control String	Hexadecimal value
<CR>	\$0D
<LF>	\$0A
<EOT>	\$04
<SOH>	\$01

4. Data transmitted by the host to the analyzer

The information described in the packet type allows the specification of the global message content: hematological routine results or statistic results.

Table 28: Data packet strings

Data packet string	Use
FILE	Order file
END	Line free message

Patient identification:

- All the described fields have a fixed size character string type and are completed with blanks on the right side for the non-significant information.
- n= number
- c= character

Table 29: Identifier list (Host to Instrument)

Identifier	Correspondance	Example	Length	Format	Transmission	See Note
\$70 p	Analyzer number	01	2+2+1	Integers	required	
\$75 u	Id # or sample id.	1450302154275-42	2+16+1	String(16)	required	
\$76 v	Id. or patient name	SMITH Ronald	2+30+1	String(30)	required	
\$77 w	Birth date	YYYYMMDD	2+8+1	nnnnnnnn	optional	4
\$78 x	Age	7d or 4w or 10m or 54y or 100	2+3+1	String(3)	advised	5
\$79 y	Sex	0, 1 or 2	2+1+1	String(1)	advised	6
\$7A z	Origin	x	2+1+1	String(1)	optional	
\$7B {	Doctor	Dr Jones	2+15+1	String(15)	optional	
\$7C	Department	Cardiology	2+10+1	String(10)	optional	
\$7D }	Collection date	16/08/99 13h15	2+14+1	DD/MM/YY HHhmm	optional	



Table 29: Identifier list (Host to Instrument)

Identifier	Correspondance	Example	Length	Format	Transmission	See Note
\$7E ~	Comments		2+32+1	String(32)	optional	
\$7F	Blood type	man	2+16+1	String(16)	optional	
\$80 ç	Analysis type	A	2+1+1	String(1)	mandatory	



- NOTE 4 (\$77)
No check on \$77 compare to \$78.
- NOTE 5 (\$78)
\$78 is a 3 characters string completed on the right side by blanks.
If age exceeded 99 years, the 3 characters of the string are used for the age without unit (example: 102).
On ABX Pentra 60C+, Age (\$78) is recalculated if Birthdate (\$77) is different.
- NOTE 6 (\$79)
0 or Blank: Unspecified, 1: Male, 2: Female
- NOTE 7 (\$7F)
\$7F must be one of the instrument blood type list. If not, it is generated according to the age (\$78) or for adults by the sex (\$79).
- NOTE 8 (\$80)
See [Table 2, "Format compatibility according to HORIBA Medical analyzers & types of analyses", page 4](#) to see test compatibility with the instrument:
'A': CBC
'B': DIF (CBC+DIF)

5. Data transmitted by the analyzer to the host

5.1. Packet type

The information described in the packet type allows the specification of the global message content: hematological routine results or statistic results.

Table 30: Packet type list

Data packet string (8 characters)	Use	Comment
RESULT	Hematological result transmission on a routine mode	
RES-RR	Hematological result transmission on automatic re-sampling mode	
REASSESS	Result transmission of a recalculated sample using the recalculation user function	
QC-RES-H	Result transmission of a high level control blood	Only available on ABX Pentra 60C+ and Pentra ES 60
QC-RES-M	Result transmission of a median level control blood	Only available on ABX Pentra 60C+ and Pentra ES 60
QC-RES-L	Result transmission of a low level control blood	Only available on ABX Pentra 60C+ and Pentra ES 60
FILE	Patient file request	
END	Connection end	



5.2. Identifier list (Instrument to Host)

Table 31: Identifier list (Instrument to Host)

Identifier	Correspondance	Example	Length	Format	See Note
\$70 p	Analyzer number	01	2+2+1	Integers	
\$71 q	Analysis date and time	23/01/05 13h49mn31s	2+19+1	String(19)	
\$72 r	Analyzer run number	115 or 005CBC06	2+16+1	String(16)	
\$73 s	Analyzer sequence number				
\$74 t	Sampling mode	M: manual (open tube) R: rack (close tube)	2+1+1	String(1)	
\$75 u	Id # or sample id.	1450302154275-42	2+16+1	String(16)	
\$76 v	Id. or patient name	SMITH Ronald	2+30+1	String(30)	
\$77 w	Birth date	16/03/72 or 03161972	2+8+1	nn/nn/nn or nnnnnnnn	
\$78 x	Age	7d or 4w or 10m or 54y or 100	2+3+1	String(3)	
\$79 y	Sex	0, 1 or 2	2+1+1	String(1)	6
\$7A z	Origin	x	2+1+1	String(1)	
\$7B {	Doctor	Dr Jones	2+15+1	String(15)	
\$7C	Department	Cardiology	2+10+1	String(10)	
\$7D }	Collection date	06/08/99 13h15	2+14+1	nn/nn/nn nnhnn	
\$7E ~	Comments		2+32+1	String(32)	
\$7F	Blood type	man	2+16+1	String(16)	7
\$80 ç	Analysis type	A	2+1+1	String(1)	8

Table 31: Identifier list (Instrument to Host)

Identifier	Correspondance	Example	Length	Format	See Note
\$81 ü	Sample rack type	0: 10 positions 1: 15 positions 2: 32 positions	2+1+1	Integer	
\$82 é	Number of runs	0, 1, ...	2+1+1	Integer	
\$83 â	Operator code	Bob	2+3+1	String(3)	

5.2.1. Numerical result fields

- Units are standard units.
- If one parameter cannot be calculated by the analyzer, the field is replaced with ---

Parameter status:

Following the numerical field, a first digit gives the counting rejection status or the suspicion, a second one gives the parameter value status according to high and low normalities, to high and low extreme values and to the overloading capacities.

Table 32: Identifier First digit

First digit (letter)	Correspondance
R	Parameter rejected for a counting default
S	Suspicious parameter value
D	Value obtained by dilution
blank	No anomaly observed

Table 33: Identifier Second digit

Second digit (letter)	Correspondance
B (french) or L (other languages)	Parameter < to the lower extreme value
b (french) or l (other languages)	Parameter < to the low normal value
blank	Parameter normal value
h	Parameter > to the high normal value
H	Parameter > to the high extreme value
C	Platelet concentrate
O	Parameter exceeding the capacity

Example: 5.5 millions RBC with a counting error in the standard units:

\$32 \$20 \$30 \$35 \$2E \$35 \$30 \$52 \$68 \$0D or
«2 05.50Rh» + carriage return.

Table 34: CBC numerical result fields list

Identifier	Correspondance	Example	Format (Length)
\$21 !	WBC	07.40	2+String(7)+1
\$32 2	RBC	04.64	2+String(7)+1
\$33 3	Hgb	14.17	2+String(7)+1
\$34 4	Hct	43.95	2+String(7)+1
\$35 5	MCV	94.68	2+String(7)+1
\$36 6	MCH	30.53	2+String(7)+1
\$37 7	MCHC	32.24	2+String(7)+1
\$38 8	RDW	12.98	2+String(7)+1
\$40 @	PLT	00401	2+String(7)+1

Table 34: CBC numerical result fields list

Identifier	Correspondance	Example	Format (Length)
\$41 A	MPV	07.94	2+String(7)+1
\$42 B	THT	0.318	2+String(7)+1
\$43 C	PDW	13.50	2+String(7)+1

Table 35: DIF numerical result fields list

Identifier	Correspondance	Example	Format (Length)
\$21 !	WBC	07.40	2+String(7)+1
\$22 "	Lymphocytes (#)	02.03	2+String(7)+1
\$23 #	Lymphocytes (%)	27.40	2+String(7)+1
\$24 \$	Monocytes (#)	00.70	2+String(7)+1
\$25 %	Monocytes (%)	09.40	2+String(7)+1
\$28 (Neutrophils (#)	04.51	2+String(7)+1
\$29)	Neutrophils (%)	60.90	2+String(7)+1
\$2A *	Eosinophils (#)	00.13	2+String(7)+1
\$2B +	Eosinophils (%)	01.70	2+String(7)+1
\$2C ,	Basophils (#)	00.04	2+String(7)+1
\$2D -	Basophils (%)	00.60	2+String(7)+1
\$2E .	Atypical Lymphocytes (#)	00.11	2+String(7)+1
\$2F /	Atypical Lymphocytes (%)	01.49	2+String(7)+1
\$30 0	Large Immature Cells (#)	00.03	2+String(7)+1
\$31 1	Large Immature Cells (%)	00.43	2+String(7)+1
\$32 2	RBC	04.64	2+String(7)+1
\$33 3	Hgb	14.17	2+String(7)+1
\$34 4	Hct	43.95	2+String(7)+1
\$35 5	MCV	94.68	2+String(7)+1
\$36 6	MCH	30.53	2+String(7)+1



Table 35: DIF numerical result fields list

Identifier	Correspondance	Example	Format (Length)
\$37 7	MCHC	32.24	2+String(7)+1
\$38 8	RDW	12.98	2+String(7)+1
\$40 @	PLT	00401	2+String(7)+1
\$41 A	MPV	07.94	2+String(7)+1
\$42 B	THT	0.318	2+String(7)+1
\$43 C	PDW	13.50	2+String(7)+1

5.2.2. Flag fields

Flags are transmitted in a comprehensive mode (same presentation than on the screen, that is to say dependant from the language).

They are replaced with blanks when the flag has not been detected.



In the following tables identifier's formats are separated by a blank only for a better comprehension.

Example of flags on WBC balance:

- \$66 \$20 BASOLMNE+BASO+ \$0D
- \$66 \$20 WBC1 \$20\$20\$20\$20\$20\$20\$20\$20\$20\$20 \$0D
- \$66 \$20 \$20\$20\$20\$20 LMNE- \$20\$20\$20\$20\$20 \$0D

Table 36: Identifier list (English and other languages)

Identifier	Parameter	Format	Length	See Note
\$50 P	WBC	L1	2+12+1	
\$51 Q	Differential	CO MB LL NL MN LN RM RN NO NE LB LI1	2+25+1	
\$52 R	RBC	MI MA	2+4+1	9
\$53 S	Plt	Pc Sc Mc	2+6+1	9

Table 36: Identifier list (English and other languages)

Identifier	Parameter	Format	Length	See Note
\$66 f	WBC balance	BASO or WBC1 or WBC2 and LMNE+ or LMNE - and BASO+ or BASO -	2+14+1	
\$67 g	General	Mp Xb Xr	2+6+1	
\$A2 I	RUOs	RUO message	2+76+1	10

Table 37: Identifier list (French)

Identifier	Parameter	Format	Length	See Note
\$50 P	GB	L1	2+12+1	
\$51 Q	Formule	Co Mb Lg Ln Mn Ng Md Nd Bf Ne Bg Lg1	2+25+1	
\$52 R	GR	MI MA	2+4+1	9
\$53 S	Plaquettes	Pc Mc Sc	2+6+1	9
\$66 f	Balance GB	BASO ou GB-1 ou GB-2 et LMNE+ ou LMNE- et Baso+ ou Baso-	2+14+1	
\$67 g	Générales	MpXbXr	2+6+1	
\$A2 I	RUOs	RUO message	2+76+1	10



- NOTE 9:
«MI» stands for MIC alarm, «MA» stands for MAC alarm, «Pc» stands for SCL alarm, «Mc» stands for MIC alarm and «Sc» stands for SCH alarm.
- NOTE 10:
«RUO message» is a warning message, always transmitted in english. Its content and size depend on the instrument.



5.2.3. Pathology messages fields

Each pathology is described by a group of 4 characters followed by a blank, except for the last pathology.

The content of the pathology is dependent from the chosen language.

Only detected pathologies are transmitted. A common header (???) to the 4 Pathology message groups indicates that the pathological interpretation is impossible.

Table 38: Identifier list

Identifier	Parameter	Format	Length
\$54 T	WBC	String of characters	2+(12(max.)x4)+1
\$55 U	RBC	String of characters	2+(7(max.)x4)+1
\$56 V	PLT	String of characters	2+(4(max.)x4)+1

When there is no pathological message, length is: 2+0+1

Table 39: Pathological format description (English and other languages)

Population	Message	Signification
WBC	LEU+ or LEU-	Leukocytosis Leukopenia
	LYM+ or LYM-	Lymphocytosis Lymphopenia
	NEU+ or NEU-	Neutrophilia Neutropenia
	EOS+	Eosinophilia
	MYEL	Myeloma
	LIMC	Large Immature Cells
	ALYM	Atypic Lymphocytes
	LSHT	Left shift
	NRBC	Nucleated Red Blood Cells
	MON+	Monocytosis

Table 39: Pathological format description (English and other languages)

Population	Message	Signification
	BAS+	Basophilia
	BLST	Blasts
RBC	ANEM	Anemia
	ANI1	Anisocytosis level 1
	MIC1 or MIC2 or MIC3	Microcytes level 1 Microcytes level 2 Microcytes level 3
	MAC1	Macrocytes level 1
	MICR	Microcytosis
	MACR	Macrocytosis
	HCR1	Hypochromia level 1
	CAGG	Cold agglutinin
	ERYT	Erythrocytosis
Plt	THR+	Thrombocytosis
	THR-	Thrombopenia
	PLAG	Platelet aggregates
	SCEL	Small cells
	MICC	Microcytes
	SCHI	Schizocytes
	MAPL	Macro platelet
All populations	???	No interpretation
	PANC	Pancytopenia



Table 40: Pathological format description (French)

Population	Messages	Signification	
GB	LEU+ or LEU-	Leucocytose Leucopénie	
	LYM+ or LYM-	Lymphocytose Lymphopénie	
	NEU+ or NEU-	Neutrophilie Neutropénie	
	EOS+	Eosinophilie	
	MYEL	Myélocémie	
	GCIM	Grandes Cellules Immatures	
	LYAT	Lymphocytes atypiques	
	FORG	Formule gauche	
	MON+	Monocytose	
	BAS+	Basophilie	
	BLST	Blastes	
	GR	ANEM	Anémie
		ANI1	Anisocytose niveau 1
		MIC1 or MIC2 or MIC3	Microcytes niveau 1 Microcytes niveau 2 Microcytes niveau 3
MAC1		Macrocytes niveau 1	
MICR		Microcytose	
MACR		Macrocytose	
HCR1		Hypochromie niveau 1	
AGGF		Agglutinine froide	
POLY		Erythrocytose	
Pla		THR+	Thrombocytose
	THR-	Thrombopénie	

Table 40: Pathological format description (French)

Population	Messages	Signification
	AGPL	Agrégats plaquettaires
	PECL	Petits éléments cellulaires
	MICC	Microcytes
	SCHI	Schizocytes
	MAPL	Macro plaquettes
Toutes populations	????	Pas d'interprétation possible
	PANC	Pancytopenie



6.2.3. PLT thresholds

The threshold 1 is the number of the last channel used to calculate the PLT number.



Diag.4: Plt histogram

6.2.4. Basophil thresholds

Thresholds 1-2-3 allow the determination of the basophil proportion regarding the total number of WBCs.

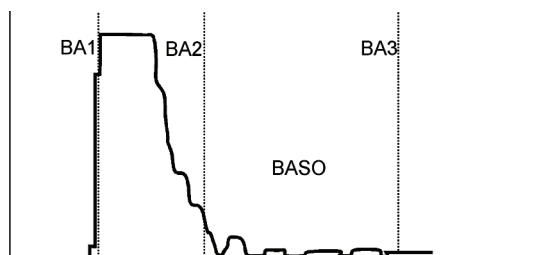

Diag.5: BASO histogram thresholds

Table 41: Histograms format description

Identifier	Parameter	Format	Length	Comments
\$57 W	WBC	Amplitude of each channel	2+128+1	
\$58 X	RBC	Amplitude of each channel	2+128+1	
\$59 Y	Plt	Amplitude of each channel	2+128+1	
\$5A Z	Basophils	Amplitude of each channel	2+128+1	
\$5D]	WBC thresholds	5 thresholds	1+20+1	
\$5E ^	RBC thresholds	2 thresholds	1+8+1	
\$5F _	PLT thresholds	1 threshold	1+4+1	
\$60 `	Basophil thresholds	3 thresholds	1+12+1	
\$6C I	WBC	extended format	see description	ABX Pentra 60 only
\$6D m	RBC	extended format	see description	ABX Pentra 60 only
\$6E n	PLT	extended format	see description	ABX Pentra 60 only
\$6F o	BASO	extended format	see description	ABX Pentra 60 only

6.3. Matrix

6.3.1. Screen bitmap

ABX Pentra 60C+ / Pentra ES 60 : 2048 graphic bytes matrix are transmitted on 4096 ASCII bytes, preceded by a blank. Each group of 2 ASCII bytes is the value of 1 graphic byte represented from the left to the right and from the top to the bottom of the screen.



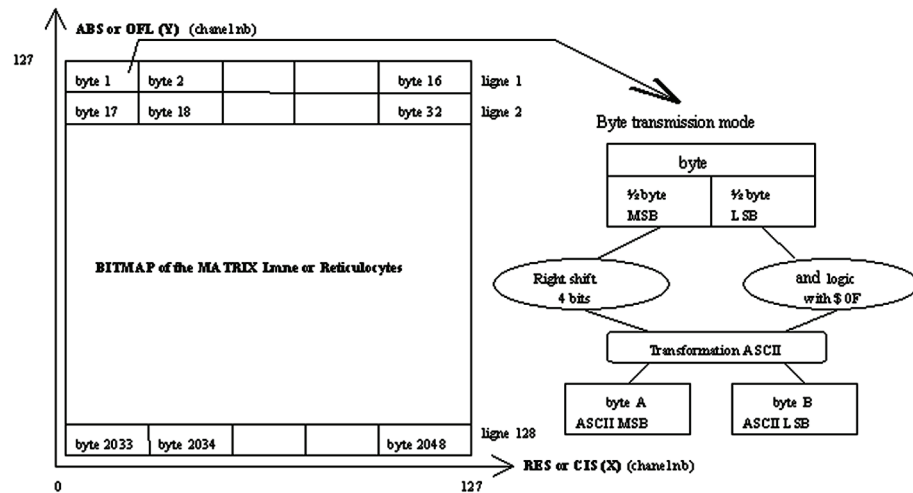

Diag.6: Matrix transmission

ABX Pentra 60 : It is constituted by a chart of 128 [ABS] x 128 [RES]. The extended format includes all the height information relative to entries of 16 bytes each. These 32K or 64K charts are first of all compressed (3k approximately for a 32K chart) then encoded (expansion 1 to 2) before being transmitted. The format is as follows: identifier, space, compression algorithm on 8 characters ("squeeze"), space, encoding type on 8 characters (od or uencode), chart format on 8 characters, space, encoded data size on 5 characters, space, data then carriage return.

6.3.2. LMNE matrix thresholds:

The 12 resistive thresholds are transmitted in the following order: NoL, NoN, NoE, LN, RN, LL, AL, LMU, LMD, LMN, MN, RM.
Resistive threshold «Channel 127» is set on channel 127 of the matrix and is not mobile

(As it is not mobile, «Channel 127» is not transmitted by the instrument).
The 3 absorbance thresholds are following: NL, NE, RMN.
At the end the width of the areas (in channel number) describing the proximity flags : FNE, FMN, FLN are transmitted.
Areas surrounded by bolt lines give the matrix populations. Population names are italicized.
Hatched areas give the sub-populations and belong to the main population.
Framed items are the proximity flags. Surrounded items are inflexion points similar to separation thresholds.

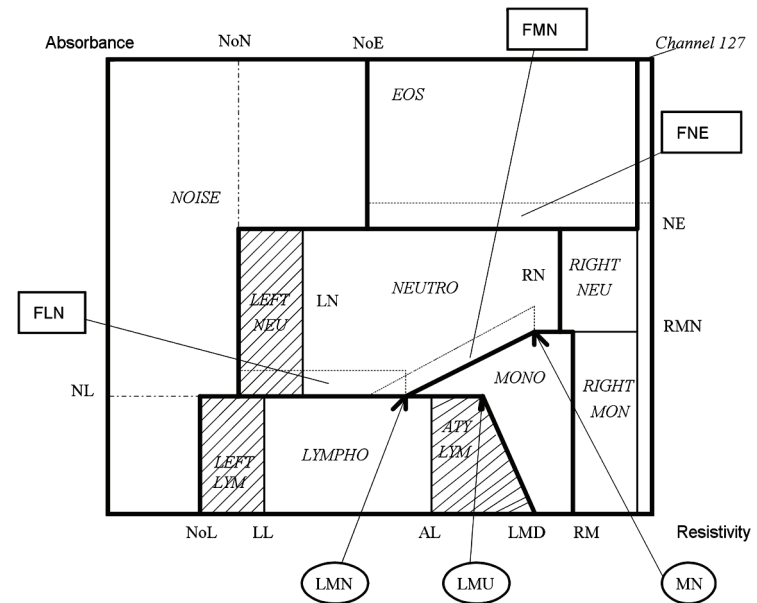

Diag.7: English LMNE matrix identifiers

Table 42: Channel Numbers for Resistive Thresholds:

Thresholds	NoL	NoN	NoE	LN	RN	LL	AL	LMU	LMD	LMN	MN	RM
Channel numbers	024	027	050	035	118	031	069	073	100	069	100	118

Channel Numbers for Absorbance Thresholds:

Thresholds	NL	NE	RMN
Channel numbers	029	077	051

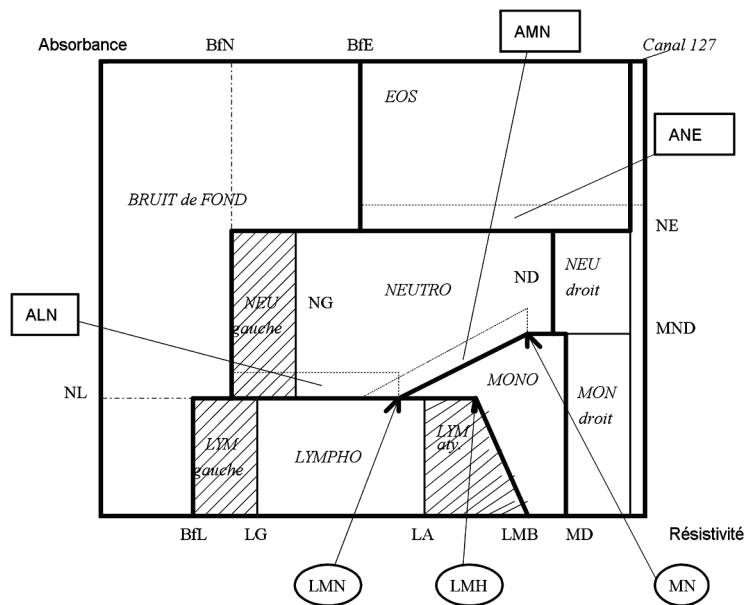

Diag.8: French LMNE matrix identifiers

Table 43: Matrix format description

Identifier	Parameter	Format	Length
\$61 a	LMNE matrix thresholds	12 RES thresholds, 6 ABS thresholds (3 of them give the proximity flags: FLN, FMN, FNE)	1+72+1
\$64 d	LMNE matrix	extended format (only on ABX Pentra 60)	see description
\$5B [LMNE matrix	Standard format	see description

6.4. Other identifiers

Identifier \$FB: Identifies the analyzer type when communicating (only on ABX Pentra 60).
 Identifier \$FC: This identifier allows the transmission of a number which can be an error number, a position number, a burn-in sequence number or a status in hexadecimal mode (Not available yet).

Identifier \$FD: Checksum value.

Identifier \$FE: The version number is linked to the development of the hematological message identifiers (only on ABX Pentra 60).



\$FC: The error list is dedicated to the "remote" mode.

\$FB and \$FF: strings < to 8 characters are completed on the right side by blanks.

Table 44: Other identifiers

Identifier	Correspondance	Format	Length
\$FB	Analyzer name (only on ABX Pentra 60)	Character string	2+8+1
\$FC	Number	8 decimal bytes	2+8+1
\$FD	16 bits check sum value	4 hexadecimal bytes	2+4+1
\$FE	Version N° of Identifier list (only on ABX Pentra 60)	String of characters: Vx.xx	2+5+1

ARGOS Format

ASTM Format is recommended by HORIBA ABX for every new connection development. Argos Format is no longer supported on new system generation.

1. Introduction

The ARGOS format is a fixed format included between STX and ETX. These characters are split into fields representing a transmitted item.

STX	DATA	CRC	ETX
-----	------	-----	-----

The data transmitted can be a result:

STX	«R» / ANALYSER # / N°ID / ID / etc..	CRC	ETX
-----	--------------------------------------	-----	-----

or a patient file:

STX	«D» / ANALYSER # / N°ID / ID / etc..	CRC	ETX
-----	--------------------------------------	-----	-----

or end of communication:

STX	«E» / ANALYSER # / etc..	CRC	ETX
-----	--------------------------	-----	-----

The fields have a fixed length separated by the \$0D character.

2. Protocol description

2.1. Typical transmission from Host to Instrument

Table 45: Typical transmission from Host to Instrument

Host	<>	Instrument	Comment
<SOH>	>		Host takes the Line
	<	<ENQ>	
<STX> + FILE + <ETX>	>		
	<	<ACK>	
	.		
	.		
	.		
<STX> + END + <ETX>	>		Host frees the Line
	<	<ACK>	

2.2. Typical transmission from Instrument to Host

Table 46: Typical transmission from Instrument to Host

Instrument	<>	Host	Comment
<SOH>	>		Instrument takes the Line
	<	<ENQ>	
<STX> + RESULT + <ETX>	>		
	<	<ACK>	
	.		
	.		



Table 46: Typical transmission from Instrument to Host

Instrument	< >	Host	Comment
	.		
<STX> + END + <ETX>	>		Instrument frees the Line
	<	<ACK>	

3. Results characteristics

3.1. Key

Total ASCII characters emitted: 406

- (-) : blank \$20
- (␣) : Carriage return \$0D
- CRC : exclusive «OR» of all the transmitted bytes except ETX and STX, then an inclusive «OR» with a \$40 value.
- zzzzz : numeric field completed by zeros on the left.
ex : 04.55 (decimal separation with a period).
- When the analyser does not transmit parameters, the field (zzzzz) is put in place of (---).-
- Y : Alphanumeric character from \$20 to \$7F.
- # : blank (\$20) if automatic sampling. Star (\$2A) if manual sampling.

Table 47: Line free format first digit (R: Reject)

First digit (letter)	Correspondance
R	Parameter rejected for a counting default
B	Incorrect balance between the counting methods
S	Suspicious parameter value
blank	No anomaly observed

Table 48: Line free format second digit (N: Normalities)

Second digit (letter)	Correspondance
L	Parameter < to the lower extreme value
l	Parameter < to the low normal value
blank	Parameter normal value
h	Parameter > to the high normal value
H	Parameter > to the high extreme value
O	Parameter exceeding the capacity

3.2. Result format

Table 49: Result format

Line	Data	Comment	Length
Line 1	STX (\$02)	Start of text	1
	R (\$44)	Character «R»	1
	zz]	Analyser No	2 + 1
Line 2	YYYYYYYYYYYYYYYY]	Identification No	16 + 1
Line 3	YYYYYYYYYYYYYYYYYYYYYYYYYYYYYYYY]	Identification	30 + 1
Line 4	zz/zz/zz-zzhzzmnzszs#]	Time & Date	20 + 1
Line 5	zzzzz-RN]	WBC	8 + 1
Line 6	zzzzz-RN]	LYM#	8 + 1
Line 7	zzzzz-RN]	LYM%	8 + 1
Line 8	zzzzz-RN]	MON#	8 + 1
Line 9	zzzzz-RN]	MON%	8 + 1
Line 10	zzzzz-RN]	GRA#	8 + 1
Line 11	zzzzz-RN]	GRA%	8 + 1
Line 12	zzzzz-RN]	NEU#	8 + 1



Table 49: Result format

Line	Data	Comment	Length
Line 13	zzzzz-RN]	NEU%	8 + 1
Line 14	zzzzz-RN]	EOS#	8 + 1
Line 15	zzzzz-RN]	EOS%	8 + 1
Line 16	zzzzz-RN]	BAS#	8 + 1
Line 17	zzzzz-RN]	BAS%	8 + 1
Line 18	zzzzz-RN]	ALY#	8 + 1
Line 19	zzzzz-RN]	ALY%	8 + 1
Line 20	zzzzz-RN]	LIC#	8 + 1
Line 21	zzzzz-RN]	LIC%	8 + 1
Line 26	zzzzz-RN]	RBC	8 + 1
Line 27	zzzzz-RN]	HGB	8 + 1
Line 28	zzzzz-RN]	HCT	8 + 1
Line 29	zzzzz-RN]	MCV	8 + 1
Line 30	zzzzz-RN]	MCH	8 + 1
Line 31	zzzzz-RN]	MCHC	8 + 1
Line 32	zzzzz-RN]	RDW	8 + 1
Line 34	zzzzz-RN]	PLT	8 + 1
Line 35	zzzzz-RN]	MPV	8 + 1
Line 36	zzzzz-RN]	PCT	8 + 1
Line 37	zzzzz-RN]	PDW	8 + 1
Line 38	ABCDEFGHIJKLMNQRSTU]	WBC 5DIFF flags	21 + 1
Line 40	PSM]	Plt Flags	3 + 1
Line 41	CRC		1
Line 42	ETX (\$03)	end of text	1
		Total:	406

Table 50: WBC 5DIFF Flags (Line 38)

Character	French	English
A	Lg	LL
B	Ln	NL
C	Mn	MN
D	Ng	LN
E	Md	RM
F	Nd	RN
G	No	NO
H	Co	CO
I	Ne	NE
J	X2	X2
K	X3	X3
L	MP	MP
M	LOW	LOW
N	LAS	LAS
O	PIT	PIT
P	Mb	MB
Q	FIT	FIT
R	NRBC	NRBC
S	Bg	LB
T	W1	W1
U	W2	W2

Table 51: PLT Flags (Line 40)

Character	French	English
P	PEC	PEC
S	SCH	SCH
M	MIC	MIC



4. Patient file characteristics

4.1. Key

- (␣) : Carriage return \$0D.
- CRC : Exclusive “OR” of all the transmitted bytes, except ETX and STX, then the inclusive “OR” with a \$40 value.
- Y, Z : Alphanumeric character from \$20 to \$7F.

4.2. Patient file format

Table 52: Patient file format

Line	Data	Comment	Length
Line 1	STX (\$02)	Start of text	1
	D (\$44)	Character «D»	1
	zz]	Analyser No	2 + 1
Line 2	YYYYYYYYYYYYYYYY]	Identification No	16 + 1
Line 3	YYYYYYYYYYYYYYYYYYYYYYYYYYYYYYYY]	Identification	30 + 1
Line 4	zz/zz/zz]	Date of birth	8 + 1
Line 5	YYY]	Age	3 + 1
Line 6	z]	Sex	1 + 1
Line 7	Y]	From	1 + 1
Line 8	YYYYYYYYYYYYYYYY]	Doctor	15 + 1
Line 9	YYYYYYYYYYYY]	Department	10 + 1
Line 10	YYYYYYYYYYYYYYYY]	Sampling date	14 + 1
Line 11	YYYYYYYYYYYYYYYYYYYYYYYYYYYYYYYY]	comments	32 + 1
Line 12	CRC		1
Line 13	ETX (\$03)	end of text	1
		Total:	147

5. End of communication

5.1. Key

- (␣) : Carriage return \$0D.
- CRC : Exclusive “OR” of all the transmitted bytes, except ETX and STX, then the inclusive “OR” with a \$40 value.
- zz : Number of the analyser.

5.2. Line free format

Table 53: Line free format

Line	Data	Comment	Length
Line 1	STX (\$02)	Start of text	1
	E (\$45)	Character «E»	1
	zz]	Analyser No	2 + 1
Line 2	CRC		1
Line 3	ETX (\$03)	end of text	1
		Total:	7

