

 **HORIBA**ABX Montpellier

ABX e-SAT Output format

RAA032AEN



Chapter 1: ASTM Format description

HORIBA ABX analyzers format responds to the ASTM specifications E-1381 & E-1394:

- E-1381: Standard specification for Low Level protocol to transfer messages between clinical and laboratory instruments and computer systems.
- E-1394: Standard specification for transferring Information between clinical and laboratory instruments and computer systems.

The ASTM LIS feature of the ABX e-SAT Data Management software allows an external LIS to communicate with one or more ABX e-SAT Data Management through one LIS serial line. This document is intended as a guide to LIS vendors developing interfaces that communicate with the ABX e-SAT Data Management System.

Table 1: Definitions

Term	Definition
<ACK>	Acknowledgment (ASCII Decimal 6)
[C1]	The most significant character of Checksum
[C2]	The least significant character of Checksum
[DATA]	The data contents of the record
<ENQ>	Inquire (ASCII Decimal 5)
<ETB>	End of Transmission Block (ASCII Decimal 23). For use only when a single record is too large to fit into one frame.
<ETX>	End of Text (ASCII Decimal 3). Required at the end of each record.
[frame number]	Single digit frame number "0" to "7", starts with "1".
<LF>	Line Feed (ASCII Decimal 10).
<NAK>	Negative Acknowledgment (ASCII Decimal 21).
<STX>	Start of Frame (ASCII Decimal 2).
Communications packet	All framing required for transmission of data. This framing includes: <STX>[frame number][DATA] [<ETB> or <ETX>][C1][C2] <LF>
Component Field	One of several related pieces of information within a field.

Table 1: Definitions

Term	Definition
Field	A specific location within a record for a piece of information, indicated by a field delimiter and position.
Frame	A complete communications packet.
LIS	Laboratory Information System
Message	A collection of related information; a group of records that begins with a «Header» record and ends with a «Terminator» record. A single record could theoretically constitute a message, but within this context, a message always contains multiple records.
Receiver	The device that responds to the sender. The receiver in this document is either the ABX e-SAT Data Management System or the LIS.
<EOT>	End of Transmission (ASCII decimal 4)
<CR>	Carriage Return (ASCII decimal 13)
Record	In reference to the low level protocol, a record is the message data (shown as [DATA]) as described within the communications packet. If the data is longer than 240 characters, then it must be split into two (or more) parts and sent in two (or more) communications packets. The intermediate packet uses the <ETB> character, and the ending packet uses the <ETX> character. No single communications packet contains more than one record. In reference to the message layer, a record can be one of the following codes: H (header), P (patient), O (order), R (result), L (terminator), C (comment).
Repeat Field	An additional field of the preceding type when indicated by a repeat delimiter. The ABX e-SAT Data Management System parses and may produce repeat fields in the Universal Test ID field of a Test Order Record or the Value field of the Result Record, but ignores other occurrences of repeat fields.
Sender	The device that has a message to send and initiate the transmission process, in this case between the LIS and the ABX e-SAT Data Management System. The sender in this document is either the ABX e-SAT Data Management System or the LIS.
Session	A total unit of communication activity used in this standard to indicate the events starting with the Establishment phase and ending with the Termination phase.
Test	A determination of a single analyte or a combination of values from other determinations or observations from which a variable or gradable result is derived.
Upload	The transmission of data from the ABX e-SAT Data Management System to the LIS.



Chapter 2: Physical connection

RS232 connection

All communications are expected to use the RS232 communication protocol, based upon the Electronics Industries Association (EIA) standard RS232-C. As part of the conformance to this standard, the ABX e-SAT Data Management System is configured as Data Terminal Equipment (DTE).

The ABX e-SAT Data Management System is cabled to the LIS via a DB-9 connector on the octopus cable plugged into the computer workstation on the ABX e-SAT.

Table 2: DB9 Connection

Pin (DB9) ABX e-SAT Data Management	LIS Port Configuration (ABX e-SAT)	LIS Cable Must Provide
3	RXD	TXD
2	TXD	RXD
7	Ground	Ground

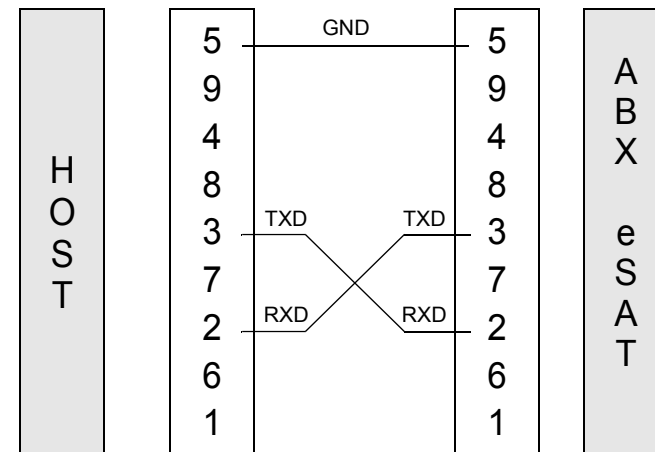



Ethernet connection

You can access and setup ethernet parameters by entering ABX e-SAT menu: «Maintenance\Settings\Peripherals\LIS».

1. FTP Mode

The instrument starts connection with FTP server just before it sends one file result, then it is disconnected.

Each file sent has a specific name «*ModuleSerialNumber_YYYYMMDDhhmmss.astm*», where *ModuleSerialNumber* is the e-SAT module serial number, and *YYYYMMDDhhmmss* is the date and time of the analyse result.

Each line of the transmitted file is a «Record» according to ASTM format.
A «Record» has no checksum.

2. UDP Mode

Host UDP socket must be setup with:

- Instrument IP address or DNS address
- The Port number where Instrument is awaiting connection

Instrument UDP socket must be setup with:

- Host IP address or DNS address
- The Port number where Host is awaiting connection (Same one used to await connection)

The data format is according to ASTM protocol.

3. TCP Mode

Host TCP socket must be setup with (Host is always server):

- Port number where Instrument will be connected

Instrument TCP socket must be setup with (Instrument is always client):

- Host IP address or DNS address
- the Port number where Host is awaiting connection

The data format is according to ASTM protocol.



Chapter 3: ASTM format

1. Connection specifications (ASTM E-1381)

1.1. Hardware and software characteristics

Default format for emitted character is 1 bit start, 8 data bits, No parity, 1 bit stop.
 Default communication speed is 9600 bauds.

Hardware setting of the interface: Plug A&B are DB9 male plugs.

1.2. Output data characteristics

Characters: ASCII
 Maximum message length: 247 characters.
 Analyzer manages Xon/Xoff protocol.

1.3. Communication protocol

Table 3: Standard control characters

Control String	Hexadecimal value
<ENQ>	\$05
<ACK>	\$06
<NAK>	\$15
<STX>	\$02
<ETX>	\$03
<CR>	\$0D
<LF>	\$0A
<EOT>	\$04

1.3.1. Instrument\Host connexion

Table 4: Typical discussion between Instrument and Host

Instrument	< >	Host
<ENQ>	>	
	<	<ACK>
<STX>1...Data...<CR><ETX>xx<CR><LF>	>	
	<	<ACK>
<STX>2...Data...<CR><ETX>xx<CR><LF>	>	
	<	<ACK>
<EOT>	>	

1.3.2. Discussion with conflict between Instrument and Host

Number of transmission if negative answer (NACK): 6
 Timeout if no response: 15s (Automatic disconnection max. time)
 Retry timeout: None
 Special timing: None
 Description of other specific treatments: None

In case of ENQ\ENQ conflict analyzer waits 2s and tries emission again.

Analyzer is master in case of conflict.



Table 5: Discussion with conflict between Instrument and Host

Instrument	< >	Host
<ENQ>	>	
	<	<ENQ>
Wait 2 second...		
<ENQ>	>	
	<	<ACK>
<STX>1...Data...<CR><ETX>xx<CR><LF>	>	
	<	<ACK>
<STX>2...Data...<CR><ETX>xx<CR><LF>	>	
	<	<ACK>
<EOT>	>	

1.3.3. Defect packet during discussion between Instrument and Host

Table 6: Defect packet during discussion between Instrument and Host

Instrument	< >	Host
<ENQ>	>	
	<	<ACK>
<STX>1...Data...<CR><ETX>xx<CR><LF>	>	
	<	<NAK>
<STX>1...Data...<CR><ETX>xx<CR><LF>	>	
	<	<ACK>
<STX>2...Data...<CR><ETX>xx<CR><LF>	>	
	<	<ACK>
<EOT>	>	

1.4. ASTM Data frame format

A sequential number located after the <STX> character is inserted into each Data frame. Frame number is set to 1 when transfer phase is initialized and is incremented by 1 for each frame up to 7 and then returns to 0.

Frame number is to permit receiver to distinguish between new and retransmitted frame, in case of retransmitted frame (after a <NAK> response from Host), frame number is not incremented: <STX>1...Data...<CR><ETX>xx<CR><LF>

Table 7: Frame format

ASTM field	Definition	Transmitted data	# of bytes	Comments
0	STX	\$02	1	
1	Frame number	1 to 7, 0, ...	1	Frame number is set to 1 and incremented by 1 for each frame up to 7 and then returns to 0
2	Data message		240 max.	Header, Patient, Order, Result & Comment messages
3	End of data message ETX if end frame		1	
4	Checksum		2	
5	CRLF	\$0D \$0A	2	

1.4.1. Frame checksum

According to ASTM E-1381 frame checksum (<STX>1...Data...<CR><ETX>xx<CR><LF>) is defined as modulo 256 of ASCII values sum between <STX> not included and <ETX> included characters: 1...Data...<CR><ETX>



2. Records general format specifications (ASTM E-1394)

Data frames encapsulate Records defined by ASTM E-1394 norm, Records themselves encapsulate ASTM fields.

Table 8: ASTM Records

Record ID	ASTM Definition	e-SAT
H	Header	X
P	Patient	X
O	Order	X
R	Result	X
C	Comment	X
Q	Query (Request information order)	X
S	Scientific Record	
M	Manufacturer informations	
L	Terminator record	X

2.1. Structure of Records

2.1.1. Structure of records for Order transmission

- H (Header)
-P (Patient)
-C (Patient Comments) Optional
-O (Order)
-C (Order Comments) Optional
- L (Terminator)

The transmission of an Order without Patient record is not allowed, but Patient record can be empty. Example: <STX>2P|1<CR><ETX>BB<CR><LF>

2.1.2. Instrument Patient file modification by Host

- H (Header)
-P (Patient)
-C (Patient Comments) Optional
- L (Terminator)

2.1.3. Structure of records for Result transmission

- H (Header)
-P (Patient)
-C (Patient Comments) Optional
-O (Order)
-C (Order Comments) Optional
-C (Run Alarms) Optional
-R (Result)
-C (Flag Result) Optional
-R (Result)
-C (Flag Result) Optional
-R (Result)
-C (Flag Result) Optional
- L (Terminator)

2.2. Description of Records

- Only the fields described with their specified length, in further tables, are used by HORIBA ABX instruments.
- Length of field can be less than maximum value but must not be more.
- Only «Sample ID» and «Test» fields from Order record must be informed, all other fields are optionals.
- Delimiter must be used even if field is free.
- Delimiters inside records are separate by «|» (ASCII \$7C).
- Delimiters inside fields are separate by «^» (ASCII \$5E).



2.2.1. Header record

Table 9: Header record fields

ASTM field	Definition	Transmitted data	Field max. length
7.1.1	Record Type	H	1
7.1.2	Delimiters definition	idem standard: Field delimiter \ Repeat delimiter ^ Component delimiter & Escape delimiter	4
7.1.3	Message Control ID		
7.1.4	Access Password		
7.1.5	Sender Name	SAT	3
7.1.6	Sender Address		
7.1.7	Reserved		
7.1.8	Sender Telephone Nb		
7.1.9	Characteristics of Sender		
7.1.10	Receiver ID		
7.1.11	Comments or Special Instructions		
7.1.12	Processing ID	P: Production message Q: Quality control message	1
7.1.13	ASTM Version Nb	E 1394-97	9
7.1.14	Date and Time of message	YYYYMMDDHHMMSS	14

2.2.2. Patient record

Table 10: Patient record fields

ASTM field	Definition	Transmitted data	Field max. length
8.1.1	Record Type	P	1
8.1.2	Sequence Nb	1, 2, ...	2
8.1.3	Practice Assigned Patient ID		
8.1.4	Laboratory Assigned Patient ID	Patient ID	16
8.1.5	Patient ID No 3		
8.1.6	Patient Name	Name^First name	40
8.1.7	Mother's Maiden Name		
8.1.8	Birthdate	YYYYMMDD	8
8.1.9	Patient Sex	M = Male F = Female	1
8.1.10	Patient Race-Ethnic Origin		
8.1.11	Patient Address		
8.1.12	Reserved		
8.1.13	Patient Telephone Nb		
8.1.14	Attending Physician ID	Text	20
8.1.15	Special Field 1		
8.1.16	Special Field 2		
8.1.17	Patient Height		
8.1.18	Patient Weight		
8.1.19	Patient's Known or Suspected Diagnosis		
8.1.20	Patient Active Medication		
8.1.21	Patient's Diet		
8.1.22	Practice Field 1		



Table 10: Patient record fields

ASTM field	Definition	Transmitted data	Field max. length
8.1.23	Practice Field 2		
8.1.24	Admission and Discharge Dates		
8.1.25	Admission Status		
8.1.26	Location	Text	20
8.1.27	Nature of Alternative Diagnostic Code and Classifiers		
8.1.28	Nature of Alternative Diagnostic Code and Classifiers		
8.1.29	Patient Religion		
8.1.30	Martial status		
8.1.31	Isolation Status		
8.1.32	Language		
8.1.33	Hospital Service		
8.1.34	Hopital Institution		
8.1.35	Dosage Category		

2.2.3. Order record

Table 11: Order record fields

ASTM field	Definition	Transmitted data	Field max. length
9.4.1	Record Type	O	1
9.4.2	Sequence Nb	1, 2, ...	2
9.4.3	Sample ID	Sample ID	16
9.4.4	Instrument Specimen ID		

Table 11: Order record fields

ASTM field	Definition	Transmitted data	Field max. length
9.4.5	Universal Test ID	^^^LMG ^^^LMG/^^^CRP	13
9.4.6	Priority		
9.4.7	Requested/Ordered Date and Time		
9.4.8	Specimen Collection Date and Time	YYYYMMDDHHMMSS	14
9.4.9	Collection End Time	YYYYMMDDHHMMSS	14
9.4.10	Collection Volume		
9.4.11	Collector ID		
9.4.12	Action Code		
9.4.13	Danger Code		
9.4.14	Relevant Clinical Informations		
9.4.15	Date/Time Specimen Received		
9.4.16	Specimen Descriptor		
9.4.17	Ordering Physician		
9.4.18	Physician Tel Nb		
9.4.19	User Field 1		
9.4.20	User Field 2		
9.4.21	Laboratory Field 1		
9.4.22	Laboratory Field 2		
9.4.23	Date and Time Results reported or last modified		
9.4.24	Instrument Charge to Computer System		
9.4.25	Instrument Section ID		
9.4.26	Report Types	F	1
9.4.27	Reserved		



Table 11: Order record fields

ASTM field	Definition	Transmitted data	Field max. length
9.4.28	Location or Ward of Specimen Collection		
9.4.29	Nosocomial Infection Flag		
9.4.30	Specimen Service		
9.4.31	Specimen institution		

2.2.4. Result record

Table 12: Result record fields

ASTM field	Definition	Transmitted data	Field max. length
10.1.1	Record Type	R	1
10.1.2	Sequence Nb	1, 2, ...	2
10.1.3	Universal Test ID	^^^parameter name in english^LOINC code	15
10.1.4	Data or Measurement Value	Test result (See "Special characteristics for HORIBA ABX datas", page 11) or "--,--"	
10.1.5	Unit or Set of units	1 = Standard 2 = International 3 = mmol 4 = japanese	1
10.1.6	Reference Range		
10.1.7	Result Abnormal Flag	Analytical flag L,H	1
10.1.8	Nature of Abnormality Testing		

Table 12: Result record fields

ASTM field	Definition	Transmitted data	Field max. length
10.1.9	Result Status	W: suspicion N: rejected result F: final result X: Parameter exceeding the capacity	1
10.1.10	Date of Change in Normative Values or Units		
10.1.11	Operator Identification		
10.1.12	Date/Time Test Starting		
10.1.13	Date/Time Test Completed	YYYYMMDDHHMMSS	14
10.1.14	Instrument Identification		

2.2.5. Comment record

Table 13: Comments record fields

ASTM field	Definition	Transmitted data	Field max. length
11.1.1	Record Type	C	1
11.1.2	Sequence Nb	1, 2, ...	2
11.1.3	Comment Source	I clinical instrument system	1
11.1.4	Comment Text	Text	100
11.1.5	Comment Type	G:Free text I: Instrument flag comment L: Comment from host	1



2.2.6. Request information record (Query mode)

Instrument request informations for only one tube at the time: 1 Request information record for each tube.

For example: See Table 18, “Example of Query”, page 13.

If Host had no information for the requested tube:

- Instrument receives an empty data frame: Only Header record and Terminator record with «Termination» code set at «I», the instrument will apply a default profile for the tube.

or

- Instrument applies default profile after a 25s timeout.

Table 14: Request information record fields

ASTM field	Definition	Transmitted data	Field max. length
12.1.1	Record Type	Q	1
12.1.2	Sequence Nb	1	1
12.1.3	Identifier	PatientID	16
12.1.4	End of identifier list		
12.1.5	Universal Test ID	ALL	3
12.1.6	Time limits		
12.1.7	Time max. limit		
12.1.8	Time min. limit		
12.1.9	Physician name		
12.1.10	Telephone number		
12.1.11	Reserve for user		
12.1.12	Reserve for user		
12.1.13	Status code	D: Query demographics only	1

2.2.7. Terminator record

Table 15: Terminator record

ASTM field	Definition	Transmitted data	Field max. length
13.1.1	Record type	L	1
13.1.2	Sequence number	1	1
13.1.3	Termination code	N: Normal	1

3. Special characteristics for HORIBA ABX datas

3.1. LMG Data presentation

Table 16: LMG Data presentation

Parameter	English code	Standard Set1	International Set2	mmol Set3	Japanese Set4
White Blood Cell	WBC	10 ³ /mm ³	10 ⁹ /L	10 ⁹ /L	10 ² /mm ³
Lymphocytes #	LYM#	10 ³ /mm ³	10 ⁹ /L	10 ⁹ /L	10 ² /mm ³
Lymphocytes %	LYM%	%	%	%	%
Monocytes #	MON#	10 ³ /mm ³	10 ⁹ /L	10 ⁹ /L	10 ² /mm ³
Monocytes %	MON%	%	%	%	%
Granulocytes #	GRA#	10 ³ /mm ³	10 ⁹ /L	10 ⁹ /L	10 ² /mm ³
Granulocytes %	GRA%	%	%	%	%
Red Blood Cell	RBC	10 ⁶ /mm ³	10 ¹² /L	10 ¹² /L	10 ⁴ /mm ³
Hemoglobin	HGB	g/dL	g/L	mmol/L	g/dL
Hematocrit	HCT	%	L/L	L/L	%



Table 16: LMG Data presentation

Parameter	English code	Standard Set1	International Set2	mmol Set3	Japanese Set4
Mean Corpuscular Volume	MCV	μm^3	fL	fL	μm^3
Mean Corpuscular Hemoglobin	MCH	pg	pg	fmol	pg
Mean Corpuscular Hemoglobin Concentration	MCHC	g/dL	g/L	mmol/L	g/dL
Red Distribution Width	RDW	%	%	%	%
Platelets	PLT	$10^3/\text{mm}^3$	$10^9/\text{L}$	$10^9/\text{L}$	$10^4/\text{mm}^3$
Mean Platelet Volume	MPV	μm^3	fL	fL	μm^3
Plateletcrit	PCT	%	$10^{-2}/\text{L}$	$10^{-2}/\text{L}$	%
Platelet Distribution Width	PDW	%	%	%	%

3.2. CRP Data presentation

Table 17: CRP data presentation

Parameter	English code	Standard Set1	International Set2	mmol Set3	Japanese Set4
C-Reactive Protein	CRP	mg/L	mg/L	mg/L	mg/dL

3.3. Alarms and Pathologies

3.3.1. Suspicion and Reject

When one result is suspected abnormal or false, that means result is not reliable, the instrument returns a flag in field 10.1.9 (See Table 12, “Result record fields”, page 10).

3.3.2. Normal and Panic ranges

Flags when result exceeds Normal or Panic ranges are transmitted through field 10.1.7, they should be compared, to get a full result information, to the ranges set by the user, these low and high limits can be transmitted through field 10.1.6 (See Table 12, “Result record fields”, page 10).

4. Management of errors

4.1. During Instrument transmission

During a single result transmission by the instrument, if the host lost the transmission (Time-Out or EOT) the full message will be transmitted again after a delay of 10s.

After 6 consecutive NAKs detected the sent order is stopped.

4.2. During Host transmission

According to E-1381 protocol, error management of Time-out, Checksum and frame number, in case of none respect of these norms, will return NAK (or communication will be halted). In case of transmission of long files (Worklist upload for example), files previously transmitted before transmission error will be interpreted and managed by the instrument, others will not be used.

All other too long fields will be cut to fit to ASTM field specified length.



5. Example of data frame

5.1. Example of Query

Table 18: Example of Query

Instrument
Host
<ENQ>
<ACK>
<STX> 1H \^& SAT P E 1397-97 20060607102544<CR><ETX>0C<CR><LF>
<ACK>
<STX> 2Q 1 PID456 ALL D<CR><ETX>2D<CR><LF>
<ACK>
<STX> 3L 1 N<CR><ETX>06<CR><LF>
<ACK>
<EOT>

5.2. Example of Result sent by instrument

Table 19: Example of Result sent by instrument (LMG test)

Instrument
Host
<ENQ>
<ACK>
<STX> 1H \^& SAT P E 1394-97 20060607103023<CR><ETX>02<CR><LF>
<ACK>
<STX> 2P 1 pid456 name^first name 19240101 M prescriptor location service <CR><ETX>E5<CR><LF>

Table 19: Example of Result sent by instrument (LMG test)

<ACK>
<STX> 3O 1 sid123 ^LGMG 060607103000 060607103000 F <CR><ETX>0F<CR><LF>
<ACK>
<STX> 4R 1 ^MPV^776-5 7.70 1 F 20060607103000 <CR><ETX>80<CR><LF>
<ACK>
<STX> 5R 2 ^PDW^X-PDW 12.90 1 F 20060607103000 <CR><ETX>12<CR><LF>
<ACK>
<STX> 6R 3 ^PLT^777-3 197.00 1 F 20060607103000 <CR><ETX>E3<CR><LF>
<ACK>
<STX> 7R 4 ^THT^X-PCT 0.15 1 F 20060607103000 <CR><ETX>E1<CR><LF>
<ACK>
<STX> 0R 5 ^HCT^4544-3 29.60 1 L F 20060607103000 <CR><ETX>16<CR><LF>
<ACK>
<STX> 1R 6 ^HGB^717-9 9.90 1 L F 20060607103000 <CR><ETX>AF<CR><LF>
<ACK>
<STX> 2R 7 ^MCH^785-6 33.80 1 H F 20060607103000 <CR><ETX>E2<CR><LF>
<ACK>
<STX> 3R 8 ^MCHC^786-4 33.50 1 F 20060607103000 <CR><ETX>DB<CR><LF>
<ACK>
<STX> 4R 9 ^MCV^787-2 101.00 1 H F 20060607103000 <CR><ETX>16<CR><LF>
<ACK>
<STX> 5R 10 ^RBC^789-9 2.93 1 L F 20060607103000 <CR><ETX>E9<CR><LF>
<ACK>
<STX> 6R 11 ^RDW^788-0 17.30 1 H F 20060607103000 <CR><ETX>20<CR><LF>
<ACK>
<STX> 7R 12 ^GRA#^20482-6 5.80 1 F 20060607103000 <CR><ETX>1B<CR><LF>
<ACK>
<STX> 0R 13 ^GRA%^14773-6 76.10 1 F 20060607103000 <CR><ETX>4E<CR><LF>



Table 19: Example of Result sent by instrument (LMG test)

```

<ACK>
<STX>1R|14|^^^LYM#^731-0|1.40|1||||F||||20060607103000|<CR><ETX>BC<CR><LF>
<ACK>
<STX>2R|15|^^^LYM%^736-9|18.90|1||||F||||20060607103000|<CR><ETX>0B<CR><LF>
<ACK>
<STX>3R|16|^^^MON#^742-7|0.30|1||||F||||20060607103000|<CR><ETX>BF<CR><LF>
<ACK>
<STX>4R|17|^^^MON%^744-3|5.00|1||||F||||20060607103000|<CR><ETX>C3<CR><LF>
<ACK>
<STX>5R|18|^^^WBC^804-5|7.50|1||||F||||20060607103000|<CR><ETX>98<CR><LF>
<ACK>
<STX>6L|1|N<CR><ETX>09<CR><LF>
<ACK>
<EOT>
  
```

Table 20: Example of Result sent by instrument (LMG+CRP test)

```

Instrument
Host
<ENQ>
<ACK>
<STX>1H|^&||SAT||||PIE 1394-97|20060607102312<CR><ETX>02<CR><LF>
<ACK>
<STX>2P|1||pid456||name^first name||19200110|M||||prescrip|||location|||||service|<CR><ETX>E1
<CR><LF>
<ACK>
<STX>3O|1|sid123|^^^LMG/^^^CRP|||060607102113|060607102113|||||||F||||<CR><ETX>45
<CR><LF>
<ACK>
  
```

Table 20: Example of Result sent by instrument (LMG+CRP test)

```

<STX>4R|1|^^^CRP^14634-0|6.00|1||||F||||20060607102113|<CR><ETX>C7<CR><LF>
<ACK>
<STX>5R|2|^^^MPV^776-5|9.70|1||||F||||20060607102113|<CR><ETX>88<CR><LF>
<ACK>
<STX>6R|3|^^^PDW^X-PDW|12.80|1||||F||||20060607102113|<CR><ETX>17<CR><LF>
<ACK>
<STX>7R|4|^^^PLT^777-3|265.00|1||||F||||20060607102113|<CR><ETX>E5<CR><LF>
<ACK>
<STX>0R|5|^^^THT^X-PCT|0.26|1||||F||||20060607102113|<CR><ETX>E1<CR><LF>
<ACK>
<STX>1R|6|^^^HCT^4544-3|23.70|1||L||F||||20060607102113|<CR><ETX>17<CR><LF>
<ACK>
<STX>2R|7|^^^HGB^717-9|8.00|1||L||F||||20060607102113|<CR><ETX>AB<CR><LF>
<ACK>
<STX>3R|8|^^^MCH^785-6|27.40|1||||F||||20060607102113|<CR><ETX>9F<CR><LF>
<ACK>
<STX>4R|9|^^^MCHC^786-4|33.80|1||||F||||20060607102113|<CR><ETX>E4<CR><LF>
<ACK>
<STX>5R|10|^^^MCV^787-2|81.20|1||||F||||20060607102113|<CR><ETX>D4<CR><LF>
<ACK>
<STX>6R|11|^^^RBC^789-9|2.92|1||L||F||||20060607102113|<CR><ETX>EE<CR><LF>
<ACK>
<STX>7R|12|^^^RDW^788-0|20.30|1||H||F||||20060607102113|<CR><ETX>20<CR><LF>
<ACK>
<STX>0R|13|^^^GRA#^20482-6|1.60|1||L||F||||20060607102113|<CR><ETX>5F<CR><LF>
<ACK>
<STX>1R|14|^^^GRA%^14773-6|71.70|1||||F||||20060607102113|<CR><ETX>55<CR><LF>
<ACK>
  
```



Table 21: Example of Result sent by instrument (LMG QC)

```
<STX>2R|15|^^^MON%^744-3|21.60|1||H||F|||20060607103717|<CR><ETX>4A<CR><LF>
<ACK>
<STX>3R|16|^^^WBC^804-5|2.80|1||H||F|||20060607103717|<CR><ETX>E9<CR><LF>
<ACK>
<STX>4L|1|N<CR><ETX>07<CR><LF>
<ACK>
<EOT>
```

Table 22: Example of Result sent by instrument (LMG+CRP QC)

```
Instrument
Host
<ENQ>
<ACK>
<STX>1H|\^&|||SAT||||Q|E 1394-97|20060607104424<CR><ETX>09<CR><LF>
<ACK>
<STX>2P|1|||1 control name||20060607|M|||||||||||||||||||<CR><ETX>30<CR><LF>
<ACK>
<STX>3O|1|1 lot|^L|^LMG/^CRP|||060607104358|060607104358||||||||||||||F|||<CR><ETX>29
<CR><LF>
<ACK>
<STX>4R|1|^CRP^14634-0|0.00|1||L||F|||20060607104358|<CR><ETX>1A<CR><LF>
<ACK>
<STX>5R|2|^MPV^776-5|8.60|1||H||F|||20060607104358|<CR><ETX>DB<CR><LF>
<ACK>
<STX>6R|3|^PLT^777-3|53.00|1||H||F|||20060607104358|<CR><ETX>03<CR><LF>
<ACK>
<STX>7R|4|^HCT^4544-3|20.20|1||H||F|||20060607104358|<CR><ETX>1C<CR><LF>
<ACK>
```

Table 22: Example of Result sent by instrument (LMG+CRP QC)

```
<STX>0R|5|^HGB^717-9|6.70|1||H||F|||20060607104358|<CR><ETX>B5<CR><LF>
<ACK>
<STX>1R|6|^MCH^785-6|26.50|1||H||F|||20060607104358|<CR><ETX>F0<CR><LF>
<ACK>
<STX>2R|7|^MCHC^786-4|33.30|1||H||F|||20060607104358|<CR><ETX>30<CR><LF>
<ACK>
<STX>3R|8|^MCV^787-2|79.50|1||H||F|||20060607104358|<CR><ETX>08<CR><LF>
<ACK>
<STX>4R|9|^RBC^789-9|2.54|1||H||F|||20060607104358|<CR><ETX>CA<CR><LF>
<ACK>
<STX>5R|10|^RDW^788-0|14.40|1||H||F|||20060607104358|<CR><ETX>2D<CR><LF>
<ACK>
<STX>6R|11|^GRA#^20482-6|2.00|1||H||F|||20060607104358|<CR><ETX>67<CR><LF>
<ACK>
<STX>7R|12|^GRA%^14773-6|65.00|1||H||F|||20060607104358|<CR><ETX>AA<CR><LF>
<ACK>
<STX>0R|13|^LYM#^731-0|0.30|1||L||F|||20060607104358|<CR><ETX>15<CR><LF>
<ACK>
<STX>1R|14|^LYM%^736-9|13.60|1||H||F|||20060607104358|<CR><ETX>5A<CR><LF>
<ACK>
<STX>2R|15|^MON#^742-7|0.50|1||L||F|||20060607104358|<CR><ETX>1C<CR><LF>
<ACK>
<STX>3R|16|^MON%^744-3|21.40|1||H||F|||20060607104358|<CR><ETX>4C<CR><LF>
<ACK>
<STX>4R|17|^WBC^804-5|2.80|1||H||F|||20060607104358|<CR><ETX>ED<CR><LF>
<ACK>
<STX>5L|1|N<CR><ETX>08<CR><LF>
<EOT>
```